



AESV / AESU / AESV-LA Series Squirrel Cage Induction Motor

AESV1S / AESU1S / AESV1S-LA (IE1) STANDARD EFFICIENCY

AESV2S / AESU2S / AESV2S-LA (IE2) HIGH EFFICIENCY

AESV3S / AESU3S / AESV3S-LA (IE3) PREMIUM EFFICIENCY

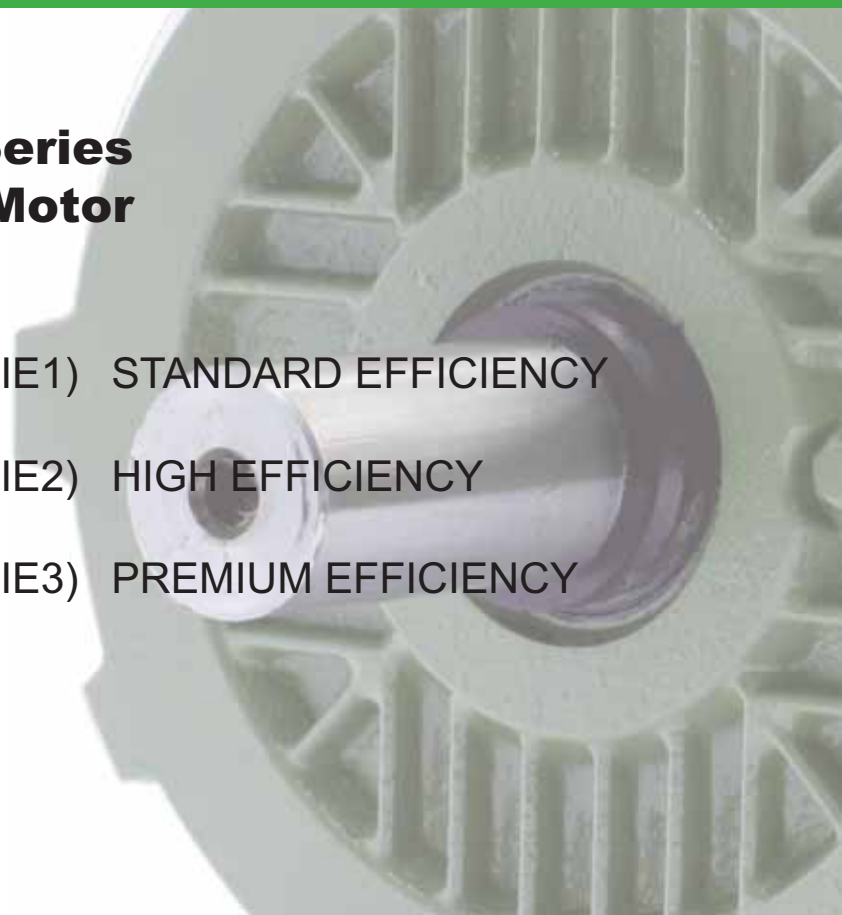

Content

Company Profile	P1
Introduction	P1-2
Design Specification	P2-3
IE1 Performance Data	P4—P8
IE2 Performance Data	P9– P12
IE3 Performance Data	P13-P16
Dimension Drawing B3	P17-P20
Dimension Drawing V1	P21-P24
Dimension Drawing B35	P25—28
Useful Formula	P29
Enquiry Form	P30

About TECO

TECO Singapore provides a total solution of motors and drives ever since it was established in 1972.

TECO Westinghouse Motor Company comprises the experience of Westinghouse, a leader in the motor industry since 1888 and TECO, a multinational conglomerate with over 50 years of motor experience. TECO Singapore itself was established in 1972 and has also set-up subsidiaries in Thailand, Malaysia, Indonesia, Vietnam and India.

By realizing the potential for precision products, especially in electronic and electrical equipment, TECO embarked a foothold in Singapore and becomes a hub for manufacturing and distribution of Electric Motors for the entire South-East Asia since 1972. TECO Singapore has established overseas manufacturing facilities and offices in Thailand, Malaysia, Indonesia, Vietnam and India.

Today, TECO is the one of the top 5 motor manufacturers in the world. Our motors are widely deployed in the industrial sectors and government projects including Singapore Mass Rapid Transit (SMRT), Land Transport Authority (LTA), Public Utilities Board (PUB), Housing Development Board (HDB) and Jurong Town Council (JTC) and Changi Airport.

Introduction to IEC 60034-30-1

Electric motor application in the industry consumes between 30% and 40% of the generated electrical energy worldwide. Improving efficiency of the complete drive system is therefore a major concern in the energy-efficiency efforts. Many different energy efficiency standards for cage induction motors from different countries were already in use (NEMA, EPACT, CSA, CEMEP, COPANT, AS/NZS, JIS, GB and others) before IEC came up with an efficiency standard. It became increasingly difficult for manufactures to design motors for a global market and for customers to understand differences and similarities of standards in different countries, therefore IEC 60034-30-1 was developed for global standards for easy reference.

IEC 60034-30-1: Efficiency classes of single-Speed, Three Phase, Cage-induction motor (IE-code)

As part of a concerted effort worldwide to reduce energy consumption, CO2 emissions and the impact of industrial operations on the environment, TECO is committed to produce International Energy-Efficiency Class (IE) motors in order to reduce the energy consumed and in turn reduce greenhouse gas emissions. TECO's V-series are designed, manufactured and tested to meet latest European and International standard. The New V Series, which comprise of full range of Efficiency Classes IE1, IE2 & IE3 Motors.

What does this standard covers?

It specifies efficiency classes for single-speed, three-phase, 50Hz and 60 Hz, cage-induction motors that have:

- Rated Voltage up to 1000V;
- Rated Output Power between 0.12kW and 1000kW;
- Either 2, 4, 6 or 8 pole;
- Rated either duty type S1 (continuous duty) or S3 (intermittent periodic duty) with a rated cycle duration factor of 80% or higher;
- Capable of operating direct on-line;
- Rated for operating conditions in accordance with IEC 60034-1, clause 6.

CEMEP (SS530)

Before this standard was published, IEC design motors mostly follow CEMEP-EU standard for efficiency classification, which is known as EFF2 (Standard Efficiency) or EFF1 (High Efficiency). The agreed minimum levels of the respective classes are based on efficiency measurements according to old EN 60034-2:1996.

SS530 is the standard used in Singapore, SS530 define the usage of the motor into two categories: 'Continuous use' & 'Occasional used'. The definition of the 'Continuous Use' is that a motor is used more than 2900 Hours a year, and 'Occasional Use' is less than 2900 hours a year. For 'Continuous Use' motor must meet a minimum nominal efficiency equivalent to CEMEP EFF 1 and 'Occasional Use' motor must meet a minimum nominal efficiency equivalent to CEMEP EFF2.

CEMEP VS IEC 60034-30-1

The method for measuring efficiency for low-voltage three phase asynchronous motor was revised with the new EN 60034-2-1:2007 standard. The new standard significantly increases the accuracy under defined laboratory conditions. IEC 60034-30, is based on the new 60034-2-1: 2007 standard for the definition of efficiency. Where else CEMEP, was based on the previous EN 60034-2:1996. In a direct comparison of the both measuring methods at the same motor, it is expected the efficiency level determine according to the new method are up to a few percentage point below the efficiency level using the old method.

Efficiency	CEMEP	IE	Model
Standard	EFF2	IE 1	AESV1S/AESU1S
High	EFF1	IE 2	AESV2S/AESU2S
Premium	-	IE 3	AESV3S/AESU3S

Electrical Design

Type: Squirrel Cage Induction Motor
Ratings: 0.18 kW ~ 375 kW

Duty Rating

All Motors have a maximum continuous duty rating of S1 under rated load. For duty cycles other than S1 please refer to TECO.

Supply Voltage

Stock motors are designed for operation as below:
2.2kW and below : 220~240V/ 380~415V 3 phase /50Hz
3 kW and above : 380~415V 3 phase /50Hz

Insulation System

All motor are design with class F insulation and Class B temperature rise at ambient temperature of 40° C. For any other insulation system other than standard Class F insulation or Class B temperature rise at higher ambient temperature than standard 40° C, please refer to TECO.

Inverter Duty

All motors are design to be suitable for Inverter use, comply with IEC 60034-17. For intensive use of Inverter duty operations complying to IEC60034-25, please refer to TECO.

Standards

IEC 60034-1 Rotating electrical machines - Part 1: Rating and performance.

IEC 60034-2-1 Rotating electrical machines - Part 2-1: Standard methods for determining losses and efficiency from tests

IEC 60034-5 Rotating electrical machines - Part 5: Degrees of protection provided by the integral design of rotating electrical machines (IP code) - classification.

IEC 60034-6 Rotating electrical machines - Part 6: Methods of cooling (IC code).

IEC 60034-7 Rotating electrical machines - Part 7: Classification of types of enclosures and mounting arrangements (IM code).

IEC 60034-8 Rotating electrical machines - Part 8: Terminal markings and direction of rotation.

IEC 60034-9 Rotating electrical machines - Part 9: Noise limits.

IEC 60034-11-1 Rotating electrical machines - Part 11-1: Thermal protection.

IEC 60034-12 Rotating electrical machines - Part 12: Starting performance of single-speed three-phase cage induction motors.

IEC 60034-14 Rotating electrical machines - Part 14: Mechanical vibration of certain machines - Limits of vibration.

IEC 60034-17 Rotating electrical machines - Part 17: Cage induction motors when fed from converters - Application guide.

IEC 60034-30-1 Rotating electrical machines - Part 30: Efficiency classes for single-speed three-phase cage induction motors.

Specification

Mechanical Design

Type: Squirrel Cage Induction Motor
Frame Size: 80M to 355C
Enclosure: Totally Enclosed Fan Cooled (TEFC), Totally Enclosed Non Ventilated (TENV)

Ingress Protection

Stock motors are design to meet Ingress Protection of IP55, other special requirement please refer to TECO.

Drive Method

Stock motors are design for both Direct Coupling and Belt Drive use from frame size 80M to 250M. However, for 2 Pole Motor design for both Direct coupling and Belt drive is from Frame size 80M to 200L only. For belt drive application for other frame size, please refer to TECO.

Bearings

High Quality Deep Groove Ball Sealed Bearings are use for our stock motor from frame size 80 to 225M and Vacuum De-Gassed High Quality Deep Groove Ball Open Bearings are use for stock motor from frame Size 250M to 355C. Any special bearings, please refer to TECO.

Lubrication

Both our sealed and open type bearing are grease lubricated.

Construction

Frame: High Grade Cast Iron
End Bracket: High Grade Cast Iron
External Fan: Polypropylene
Fan Cover: Pressed Steel
Shaft: Carbon Steel
Lead: 6 Leads
Iron Core: High Grade, Insulated, Cold Rolled,
Electro Magnetic Steel Plate

Terminal Box

Stock motor are fitted with pressed steel T-Box for Frame 80M to 180M and Cast Iron T-Box for frame 200L to 355M. T-Box are designed for provision of rotation by 90° to every direction that enable cable entry from 4 directions.

Finishing

Stock motor are completed with Phenolic Rust Proof Base Plus Lacquer Surface Finished Painting as standard:
Gray Color (Munsell 7.5B 3.5/0.5) (IE 1)
Blue Color (Munsell 5PB 3/8) (IE 2)
Green Color (Munsell 7.5GY 4.5/3.5) (IE 3)
Any other colour finishing, please refer to TECO.

Lifting Device

All motor from Frame Size 90 and above comes with dual eye bolt for lifting purposes.

Standards

IEC 60072-1 Dimensions and output series for rotating electrical machines - Part 1: Frame numbers 56 to 400 and flange numbers 55 to 1080.

Connection Diagram

Direct-On-Line

For motor rating 2.2kW and below:
Low Voltage: 220~240V
High Voltage: 380~415V

For motor rating 3kW and above:
Low Voltage: 380~415V

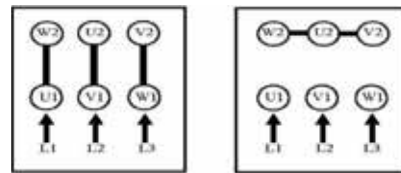

Star-Delta

Connect U1,V1,W1,U2,V2 & W2 to Star-Delta starter panel.

Power Supply Voltage(L1,L2,L3) to be connected to voltage indicated in Delta configuration column on the motor nameplate.

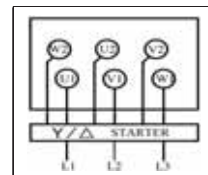

Special Enhancement

The following enhancement are also available. Please refer to TECO.

- IP 56
- Class 'H' Insulation
- Inverter Duty Wire
- Special Paint Finishes
- Special Shaft Extensions
- Dual Speed
- Smoke Spill Duty
- Stainless Steel Hardware
- Conversion of sealed bearing to open bearing

Optional Accessories

Thermal Protection Accessories

PTC Thermistors
Resistance Temperature Detectors (RTD)
Thermostat

Moisture Protection Accessories

Space Heater

IE 1 Performance Data

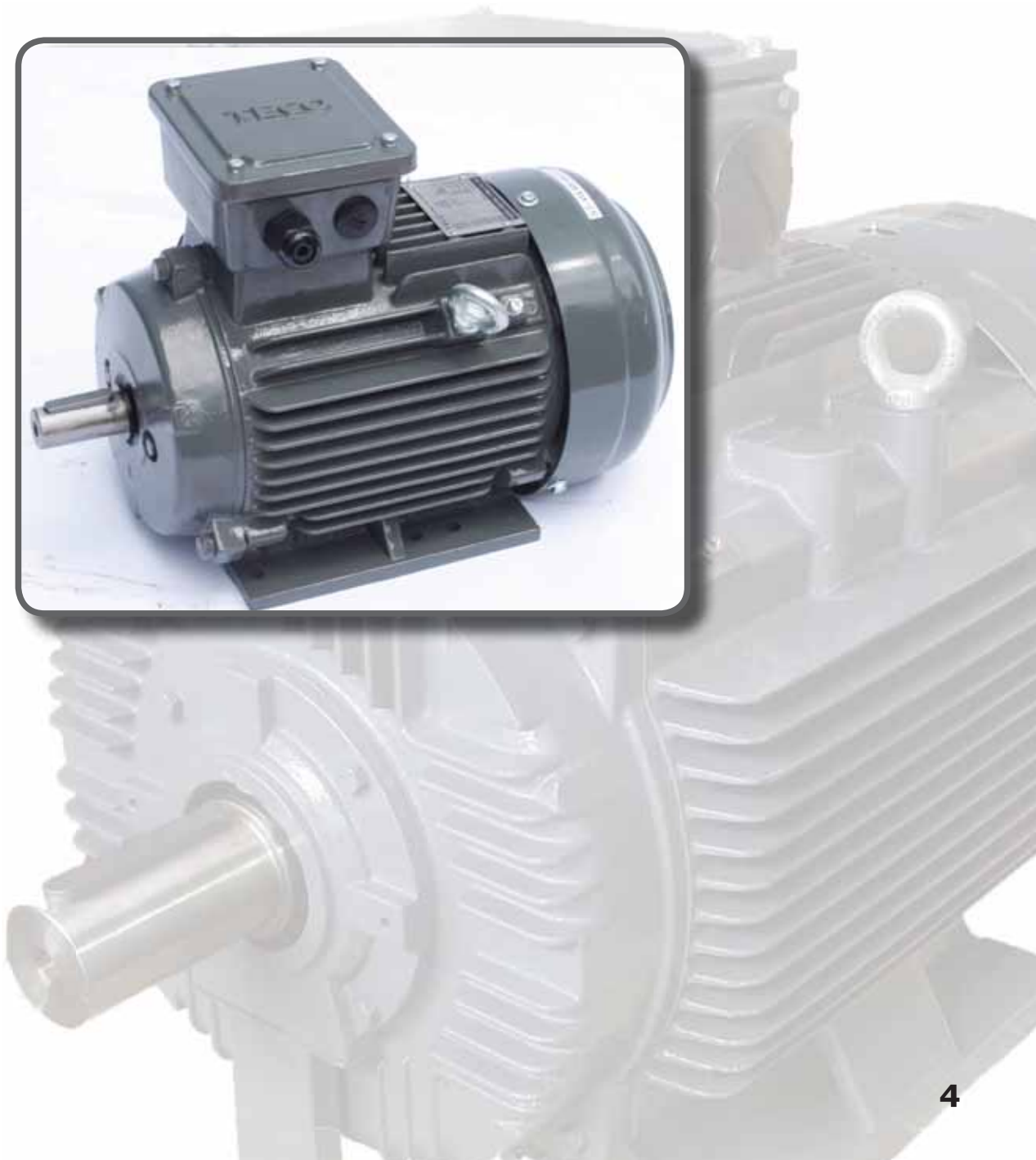

IE 1 Performance Data (2 Pole)

Motor Type AESV1S / AESU1S / AESV1S-LA

OUTPUT		FULL LOAD rpm	FRAME SIZE	EFFICIENCY			POWER FACTOR			CURRENT				TORQUE					APPROX. WEIGHT kg
kW	HP			FULL LOAD (%)	3/4 LOAD (%)	1/2 LOAD (%)	FULL LOAD (%)	3/4 LOAD (%)	1/2 LOAD (%)	FULL LOAD (A)			LRC (A)	FULL LOAD kg-m	LOCKED ROTOR %FLT	PULL-UP %FLT	BREAK-DOWN %FLT	ROTOR GD ² kg-m ²	
										380	400	415							
0.75	1	2800	80M	72.1	71.6	68.8	88.0	81.0	68.0	1.80	1.71	1.64	11	0.261	235	210	255	0.005	16.5
1.1	1.5	2810	80M	75.0	75.9	74.5	87.5	81.0	70.0	2.55	2.42	2.33	17	0.381	265	235	290	0.006	18.0
1.5	2	2850	90S	77.2	77.2	75.3	88.0	82.0	70.5	3.35	3.19	3.07	21	0.512	225	210	290	0.010	23.0
2.2	3	2855	90L	79.7	80.7	79.7	89.0	84.0	74.0	4.71	4.48	4.31	33	0.750	240	230	310	0.013	27.0
3	4	2890	100L	81.5	82.0	80.5	89.0	85.0	76.0	6.28	5.97	5.75	50	1.010	215	195	280	0.022	37.5
3.7	5	2880	112M	82.6	83.6	81.6	90.0	87.0	79.0	7.56	7.18	6.92	62	1.250	240	180	320	0.042	47.5
4	5.5	2910	112M	83.1	84.1	83.1	90.5	87.5	79.5	8.08	7.68	7.40	67	1.337	200	170	325	0.042	47.5
5.5	7.5	2900	132S	84.7	83.7	81.3	88.0	85.5	79.0	11.2	10.7	10.3	69	1.845	170	150	235	0.057	61.0
7.5	10	2895	132S	86.0	86.0	84.5	82.0	80.0	76.0	16.2	15.4	14.8	91	2.521	170	145	225	0.063	65.0
11	15	2945	160M	87.6	87.6	85.6	89.0	85.5	77.5	21.4	20.4	19.6	176	3.634	225	140	280	0.154	105
15	20	2940	160M	88.7	89.2	88.2	91.0	90.0	85.5	28.2	26.8	25.9	210	4.964	220	135	260	0.192	120
18.5	25	2940	160L	89.3	89.8	89.3	92.0	90.0	85.5	34.2	32.5	31.3	291	6.123	270	190	310	0.237	135
22	30	2945	180M	89.9	89.9	88.9	90.0	88.0	83.5	41.3	39.2	37.8	314	7.269	220	175	280	0.283	175
30	40	2955	200L	90.7	90.2	87.7	84.5	79.0	71.0	59.5	56.5	54.5	441	9.878	185	140	275	0.521	240
37	50	2955	200L	91.2	91.2	90.2	88.5	87.0	81.0	69.6	66.2	63.8	527	12.18	195	135	270	0.633	270
45	60	2955	225MA	91.7	91.2	89.7	91.5	90.0	86.0	81.5	77.4	74.6	600	14.82	150	130	260	1.074	315
55	75	2970	250MA	92.1	92.1	91.1	91.0	90.0	85.5	99.7	94.7	91.3	697	18.02	135	115	295	1.211	405
75	100	2970	280SA	92.7	92.7	91.4	87.0	85.0	80.0	141	134	129	966	24.57	130	120	260	1.759	515
90	125	2965	280MA	93.0	92.8	91.9	87.0	84.0	76.5	169	161	155	1157	29.53	140	120	290	2.023	552
110	150	2970	315SA	93.5	93.5	92.8	89.0	87.0	81.0	201	191	184	1330	36.09	135	115	230	3.600	800
132	175	2970	315MA	93.7	93.7	93.0	89.5	88.5	83.5	239	227	219	1570	43.31	145	120	230	4.400	900
(160)	(215)	2970	315MA	94.0	94.0	93.2	91.5	90.5	86.0	283	269	259	2050	52.50	210	175	240	5.200	950
160	215	2970	315LA	94.0	94.0	93.2	91.5	90.5	86.0	283	269	259	2050	52.50	210	175	240	5.200	980
200	270	2970	315LA	94.0	94.0	93.4	92.0	91.0	87.5	351	334	322	2500	65.62	210	175	240	6.400	1100
(220)	(300)	2970	315CA	94.4	94.0	92.8	90.5	89.0	83.5	391	372	358	2800	72.18	150	125	270	7.200	1380
220	300	2975	355MA	94.5	94.0	93.0	90.0	88.0	81.0	393	373	360	2840	72.06	140	115	280	10.40	1550
(250)	(335)	2972	315CA	94.6	94.1	93.0	92.0	91.0	87.5	436	415	400	3100	81.97	150	125	270	8.400	1500
250	335	2978	355MA	94.6	94.2	93.3	91.0	89.0	83.5	441	419	404	3180	81.81	150	125	280	12.00	1650
(315)	(420)	2975	315DA	94.8	94.4	93.5	92.5	91.5	88.0	546	518	500	3900	103.2	160	130	280	10.40	1720
315	420	2978	355LA	94.8	94.4	93.5	91.5	90.0	86.0	552	524	505	3900	103.1	150	125	280	14.00	1900
375	500	2980	355CA	94.8	94.8	93.7	92.0	90.5	86.5	653	621	598	4500	122.6	150	125	280	12.40	2340

Note:

1. The above are typical values based on test according to IEC 60045-2-1:2007. (DY)
2. Tolerance according to IEC 60034-1.
3. Breakdown & Locked rotor torques are show as average expected voltages
4. Efficiency, power factor, speed and torque are the same for other voltages.
Current values vary inversely with voltage
5. Output in () is for Optional Frame size upon request
6. Frame size 315C, 315D & 355C: only suitable for IM B3 and IM B5
7. Noise according to IEC 60034-9.
8. Data subject to change without prior notice.

IE 1 Performance Data (4 Pole)

Motor Type AESV1S / AESU1S / AESV1S-LA

OUTPUT		FULL LOAD rpm	FRAME SIZE	EFFICIENCY			POWER FACTOR			CURRENT				TORQUE					APPROX. WEIGHT kg
kW	HP			FULL LOAD (%)	3/4 LOAD (%)	1/2 LOAD (%)	FULL LOAD (%)	3/4 LOAD (%)	1/2 LOAD (%)	FULL LOAD (A)			LRC (A)	FULL LOAD kg-m	LOCKED ROTOR %FLT	PULL-UP %FLT	BREAK-DOWN %FLT	ROTOR GD ² kg-m ²	
										VOLTAGE									
										380	400	415							
0.55	0.75	1425	80M	70.0	68.9	62.1	73.0	62.5	50.0	1.64	1.55	1.50	9.0	0.376	220	200	265	0.007	15.0
0.75	1	1425	80M	72.1	71.6	68.3	77.0	66.0	52.5	2.05	1.95	1.88	12	0.512	240	215	275	0.009	16.5
1.1	1.5	1425	90S	75.0	75.0	68.1	79.0	68.5	55.5	2.82	2.68	2.58	17	0.751	220	165	235	0.014	22.0
1.5	2	1425	90L	77.2	77.2	74.2	81.0	72.5	59.0	3.64	3.46	3.34	23	1.024	230	175	240	0.017	24.0
2.2	3	1435	100L	79.7	79.7	77.2	79.5	71.0	57.0	5.28	5.01	4.83	39	1.492	210	185	300	0.033	32.0
3	4	1445	100L	81.5	80.9	77.5	85.0	76.0	63.0	6.58	6.25	6.02	52	2.020	250	180	300	0.046	37.5
3.7	5	1445	112M	82.6	82.6	80.6	82.0	74.5	64.0	8.30	7.88	7.60	62	2.491	220	180	290	0.059	44.5
4	5.5	1445	112M	83.1	83.6	81.7	82.0	76.0	64.0	8.92	8.47	8.17	60	2.693	190	180	260	0.065	47.5
5.5	7.5	1465	132S	84.7	84.7	83.2	82.5	75.5	63.5	12.0	11.4	11.0	86	3.653	235	190	315	0.103	64.0
7.5	10	1460	132M	86.0	86.5	85.0	86.0	81.5	71.5	15.4	14.6	14.1	109	4.998	215	175	295	0.133	78.0
11	15	1465	160M	87.6	88.1	87.1	86.5	82.5	74.5	22.1	21.0	20.2	155	7.306	200	150	255	0.271	105
15	20	1465	160L	88.7	88.7	87.2	86.0	80.5	71.0	29.9	28.4	27.4	217	9.962	215	155	265	0.396	130
18.5	25	1475	180M	89.3	89.3	88.8	86.0	83.5	76.5	36.6	34.8	33.5	220	12.20	165	125	220	0.611	175
22	30	1475	180L	89.9	89.9	88.9	84.0	80.5	72.5	44.3	42.0	40.5	299	14.51	195	150	230	0.712	190
30	40	1475	200L	90.7	91.2	90.7	86.5	83.5	76.5	58.1	55.2	53.2	444	19.79	240	185	275	1.220	255
37	50	1480	225SC	91.2	90.7	89.7	85.0	81.5	74.5	72.5	68.9	66.4	489	24.33	190	160	245	1.649	315
45	60	1475	225MC	91.7	92.2	91.2	85.5	83.0	76.5	87.2	82.8	79.8	523	29.68	175	145	220	1.731	330
55	75	1485	250MC	92.1	92.1	91.1	87.0	85.0	79.5	104	99.1	95.5	714	36.04	220	110	230	2.755	450
75	100	1480	280SB	92.7	92.7	92.2	84.5	81.0	73.5	145	138	133	948	49.31	175	165	275	4.224	566
90	125	1480	280MB	93.0	93.2	92.5	85.5	82.5	72.5	172	163	157	1164	59.17	175	165	270	4.943	624
110	150	1480	315SB	93.5	93.5	92.9	86.5	83.5	75.5	207	196	189	1330	72.43	190	155	250	7.200	800
132	175	1480	315MB	93.7	93.7	93.2	86.5	83.0	74.5	247	235	227	1570	86.91	200	165	250	8.400	900
(160)	(215)	1482	315MB	94.0	94.0	93.4	87.5	84.5	77.0	296	281	271	2000	105.2	200	165	250	10.00	960
160	215	1482	315LB	94.0	94.0	93.4	87.5	84.5	77.0	296	281	271	2000	105.2	200	165	250	10.00	990
200	270	1482	315LB	94.0	94.1	93.6	88.5	86.0	79.0	365	347	334	2500	131.5	210	175	250	13.20	1160
(220)	(300)	1484	315CB	94.5	94.5	93.7	89.5	88.0	82.5	395	375	362	2840	144.5	200	165	250	19.20	1420
220	300	1486	355MB	94.5	94.3	93.4	87.8	85.0	78.4	403	383	369	2750	144.3	180	160	250	20.40	1550
(250)	(335)	1485	315CB	94.6	94.5	93.8	89.5	87.5	82.0	449	426	411	3150	164.1	200	165	260	21.20	1500
250	335	1486	355MB	94.6	94.4	93.8	88.0	85.5	78.0	456	433	418	3150	163.9	190	155	270	23.20	1650
(315)	(420)	1485	315DB	94.9	94.9	94.4	90.0	88.0	82.5	560	532	513	4100	206.7	200	165	260	26.40	1780
315	420	1486	355LB	94.9	94.8	94.3	88.8	86.3	79.5	568	540	520	3900	206.6	200	165	270	28.80	1900
375	500	1486	355CB	94.9	94.9	94.4	89.5	88.0	82.0	671	637	614	4500	245.9	200	165	270	34.80	2340

Note:

1. The above are typical values based on test according to IEC 60045-2-1:2007. (DY)
2. Tolerance according to IEC 60034-1.
3. Breakdown & Locked rotor torques are show as average expected voltages
4. Efficiency, power factor, speed and torque are the same for other voltages.
Current values vary inversely with voltage
5. Output in () is for Optional Frame size upon request
6. Frame size 315C, 315D & 355C: only suitable for IM B3 and IM B5
7. Noise according to IEC 60034-9.
8. Data subject to change without prior notice.

IE 1 Performance Data (6 Pole)

Motor Type AESV1S / AESU1S / AESV1S-LA

OUTPUT		FULL LOAD rpm	FRAME SIZE	EFFICIENCY			POWER FACTOR			CURRENT				TORQUE					APPROX. WEIGHT kg
kW	HP			FULL LOAD (%)	3/4 LOAD (%)	1/2 LOAD (%)	FULL LOAD (%)	3/4 LOAD (%)	1/2 LOAD (%)	FULL LOAD (A)			LRC (A)	FULL LOAD kg-m	LOCKED ROTOR %FLT	PULL-UP %FLT	BREAK-DOWN %FLT	ROTOR GD ² kg-m ²	
										VOLTAGE									
										380	400	415	400V						
0.55	0.75	915	80M	67.5	67.0	62.0	72.0	60.5	48.0	1.72	1.63	1.57	8.0	0.585	220	210	225	0.012	18.0
0.75	1	935	90S	70.0	67.2	62.9	71.0	60.5	48.0	2.29	2.18	2.10	11	0.780	190	175	285	0.017	24.0
1.1	1.5	935	90L	72.9	71.0	66.1	68.5	57.0	44.5	3.35	3.18	3.06	17	1.145	220	205	260	0.023	27.5
1.5	2	935	100L	75.2	75.2	69.8	75.0	65.0	52.0	4.04	3.84	3.70	21	1.561	200	170	235	0.035	31.5
2.2	3	950	112M	77.7	77.7	74.8	73.5	63.0	50.0	5.85	5.56	5.36	34	2.253	205	195	270	0.058	42.5
3	4	965	132S	79.7	79.7	77.3	72.5	63.5	50.0	7.89	7.49	7.22	45	3.025	195	185	270	0.097	57.5
3.7	5	960	132M	80.9	80.9	75.9	75.5	65.5	53.5	9.20	8.74	8.43	61	3.750	180	160	230	0.114	62.5
4	5.5	960	132M	81.4	81.9	80.4	77.5	69.5	56.5	9.63	9.15	8.82	59	4.054	190	175	275	0.131	69.0
5.5	7.5	965	132M	83.1	82.6	81.1	72.0	63.5	50.0	14.0	13.3	12.8	92	5.546	210	160	280	0.171	77.5
7.5	10	960	160M	84.7	83.7	81.3	81.5	76.5	66.0	16.5	15.7	15.1	94	7.602	210	185	255	0.363	110
11	15	965	160L	86.4	86.9	85.9	81.5	76.0	65.0	23.7	22.5	21.7	155	11.09	245	230	270	0.558	140
15	20	970	180L	87.7	88.2	87.7	82.0	79.5	73.5	31.7	30.1	29.0	178	15.05	195	140	210	1.342	195
18.5	25	975	200L	88.6	88.6	87.6	82.5	79.0	70.5	38.5	36.5	35.2	223	18.46	200	185	220	1.604	250
22	30	975	200L	89.2	89.7	89.7	82.0	78.5	69.5	45.7	43.4	41.8	296	21.95	210	180	220	1.912	270
30	40	975	225MC	90.2	90.2	87.2	86.0	83.5	76.0	58.8	55.8	53.8	344	29.94	175	155	210	2.442	325
37	50	975	250MC	90.8	90.8	89.8	85.5	81.0	73.0	72.4	68.8	66.3	451	36.92	185	180	220	3.373	405
45	60	980	280SB	91.4	91.5	90.7	82.5	79.5	71.0	90.7	86.1	83.0	597	44.68	150	140	230	4.400	500
55	75	980	280MB	91.9	92.0	91.3	83.5	80.5	72.0	109	103	99.7	680	54.61	150	140	235	5.290	557
75	100	985	315SB	92.6	92.7	92.1	84.5	81.5	72.5	146	138	133	840	74.20	160	130	230	10.40	800
90	125	985	315MB	93.0	93.0	92.5	84.5	81.5	72.0	174	165	159	1070	89.04	175	145	230	12.80	880
(110)	(150)	988	315MB	93.5	93.5	93.0	84.5	81.5	72.5	212	201	194	1295	108.5	175	145	230	15.60	960
110	150	988	315LB	93.5	93.5	93.0	84.5	81.5	72.5	212	201	194	1295	108.5	175	145	230	15.60	990
132	175	988	315LB	93.7	93.7	93.2	84.0	80.0	71.0	255	242	233	1530	130.2	210	175	240	17.20	1120
(160)	(215)	988	315LB	94.0	94.0	93.4	84.8	81.6	73.5	305	290	279	1950	157.8	210	175	240	23.20	1270
160	215	990	355MB	94.0	94.0	93.4	86.0	83.0	75.0	301	286	275	2054	157.5	180	160	300	28.00	1550
(200)	(270)	988	315CB	94.2	94.2	93.8	85.5	83.0	74.0	377	358	345	2360	197.3	200	165	240	30.80	1650
200	270	990	355MB	94.0	94.0	93.6	86.0	83.0	75.0	376	357	344	2450	196.9	200	165	240	33.60	1750
(220)	(300)	988	315CB	94.5	94.5	94.0	86.5	84.5	78.0	409	388	374	2550	217.0	180	160	240	35.20	1740
220	300	990	355MB	94.5	94.5	94.0	86.0	83.5	76.0	411	391	377	2700	216.6	200	165	240	37.60	1800
(250)	(335)	988	315DB	94.6	94.6	94.2	86.5	85.0	78.5	464	441	425	2950	246.6	200	165	240	41.20	1860
250	335	988	355LB	94.6	94.6	94.2	86.0	83.0	75.5	467	444	428	3050	246.6	200	165	250	41.20	1950
315	420	990	355CB	94.8	94.8	94.4	87.5	85.5	79.0	577	548	528	3830	310.1	210	175	240	56.00	2600

Note:

1. The above are typical values based on test according to IEC 60045-2-1:2007. (DY)
2. Tolerance according to IEC 60034-1.
3. Breakdown & Locked rotor torques are show as average expected voltages
4. Efficiency, power factor, speed and torque are the same for other voltages.
Current values vary inversely with voltage
5. Output in () is for Optional Frame size upon request
6. Frame size 315C, 315D & 355C: only suitable for IM B3 and IM B5
7. Noise according to IEC 60034-9.
8. Data subject to change without prior notice.

IE 1 Performance Data (8 Pole)

Motor Type AESV1S / AESU1S / AESV1S-LA

OUTPUT		FULL LOAD rpm	FRAME SIZE	EFFICIENCY			POWER FACTOR			CURRENT				TORQUE					APPROX. WEIGHT kg
kW	HP			FULL LOAD (%)	3/4 LOAD (%)	1/2 LOAD (%)	FULL LOAD (%)	3/4 LOAD (%)	1/2 LOAD (%)	FULL LOAD (A)			LRC (A)	FULL LOAD kg-m	LOCKED ROTOR %FLT	PULL-UP %FLT	BREAK-DOWN %FLT	ROTOR GD ² kg-m ²	
										380	400	415							
0.18	0.25	710	80M	50.0	44.5	36.0	46.5	40.0	34.0	1.18	1.12	1.08	4.7	0.247	360	350	370	0.010	17.0
0.37	0.5	705	90S	59.5	56.7	50.5	61.5	52.0	41.5	1.54	1.46	1.41	5.0	0.511	180	170	240	0.017	24.0
0.55	0.75	700	90L	63.6	61.7	55.7	61.5	53.0	42.0	2.14	2.03	1.96	7.3	0.765	180	150	250	0.022	26.0
0.75	1	700	100L	66.7	65.2	59.8	66.0	56.5	45.5	2.59	2.46	2.37	9.4	1.043	180	160	210	0.033	29.0
1.1	1.5	690	100L	70.2	69.7	65.4	67.5	59.0	47.0	3.53	3.35	3.23	15	1.551	200	175	210	0.046	34.5
1.5	2	705	112M	72.8	72.3	68.5	67.0	59.0	46.5	4.67	4.44	4.28	20	2.070	160	135	215	0.065	41.0
2.2	3	700	132S	75.9	75.9	73.6	72.5	64.0	51.0	6.07	5.77	5.56	26	3.058	190	175	225	0.115	54.0
3	4	700	132M	78.1	78.6	76.4	73.0	65.0	52.0	7.99	7.59	7.32	34	4.170	190	175	220	0.138	60.0
3.7	5	720	160M	79.4	79.4	77.4	71.0	62.5	49.0	9.97	9.47	9.13	59	5.000	200	180	270	0.265	83.0
4	5.5	720	160M	80.0	80.3	78.2	71.5	64.0	51.5	10.6	10.1	9.73	59	5.406	200	180	270	0.265	83.0
5.5	7.5	720	160M	82.0	82.4	80.5	72.0	64.5	52.5	14.2	13.4	13.0	81	7.433	200	180	270	0.374	98.0
7.5	10	720	160L	83.8	84.3	82.7	73.5	66.5	54.5	18.5	17.6	16.9	107	10.14	200	190	270	0.530	115
11	15	725	180L	85.8	86.3	85.3	75.0	68.0	55.5	26.0	24.7	23.8	138	14.76	190	170	215	0.990	156
15	20	725	200L	87.2	87.8	86.8	76.5	70.5	59.0	34.2	32.5	31.3	164	20.13	190	170	205	1.418	224
18.5	25	730	225SC	88.1	88.1	87.1	78.0	72.0	62.0	40.9	38.9	37.5	236	24.66	185	150	200	2.093	288
22	30	730	225MC	88.8	88.3	86.8	77.0	70.5	59.0	48.9	46.4	44.8	281	29.32	200	175	210	2.442	316
30	40	730	250MC	89.9	89.4	87.9	78.5	70.5	60.0	64.6	61.4	59.1	378	39.99	190	160	210	3.475	389
37	50	735	280SB	90.6	91.0	90.4	77.5	78.5	75.0	80.1	76.1	73.3	495	48.98	130	125	210	5.553	553
45	60	735	280MB	91.2	91.6	91.1	78.0	79.2	76.0	96.1	91.3	88.0	595	59.57	135	125	210	6.760	624
55	75	735	315SB	92.5	92.5	91.8	79.5	75.0	64.0	114	108	104	630	72.92	165	135	220	15.20	840
75	100	735	315MB	92.7	92.7	92.0	80.5	76.0	66.0	153	145	140	820	99.44	160	130	220	19.60	960
90	125	735	315LB	93.0	93.0	92.3	81.0	77.0	67.5	182	172	166	1000	119.3	160	130	220	23.60	1060
110	150	735	315LB	93.5	93.5	92.9	81.0	78.0	68.5	221	210	202	1250	145.8	160	130	220	30.40	1160
(132)	(175)	740	315CB	93.9	93.9	93.1	79.5	74.5	60.0	269	255	246	1550	173.8	110	95	230	28.00	1550
132	175	740	355MB	93.9	93.9	93.1	82.5	78.5	69.0	259	246	237	1950	173.8	120	100	240	34.00	1600
(160)	(215)	740	315CB	94.3	94.3	93.8	80.5	75.5	65.0	320	304	293	1850	210.7	110	95	230	34.40	1650
160	215	740	355MB	94.3	94.3	93.8	82.5	78.5	69.0	312	297	286	1950	210.7	130	110	240	39.60	1750
(200)	(270)	740	315DB	94.4	94.4	93.8	80.5	75.0	64.5	400	380	366	2300	263.4	110	95	230	41.20	1800
200	270	740	355LB	94.4	94.4	93.8	83.0	79.0	69.5	388	368	355	2550	263.4	130	110	240	52.00	2000
(220)	(300)	740	315DB	94.6	94.6	94.1	80.5	75.0	64.5	439	417	402	2550	289.7	110	95	230	45.60	1900
220	300	740	355LB	94.6	94.6	94.1	83.5	80.0	71.5	423	402	387	2700	289.7	125	105	240	56.40	2100
250	335	740	355CB	94.8	94.8	94.3	83.5	80.0	71.0	480	456	439	3200	329.2	135	110	240	67.60	2400

Note:

1. The above are typical values based on test according to IEC 60045-2-1:2007. (DY)
2. Tolerance according to IEC 60034-1.
3. Breakdown & Locked rotor torques are show as average expected voltages
4. Efficiency, power factor, speed and torque are the same for other voltages.
Current values vary inversely with voltage
5. Output in () is for Optional Frame size upon request
6. Frame size 315C, 315D & 355C: only suitable for IM B3 and IM B5
7. Noise according to IEC 60034-9.
8. 8 pole : Efficiency per TECO performance standard (Comply to min. requirement of IE1 efficiency).
9. Data subject to change without prior notice.

IE 2 Performance Data

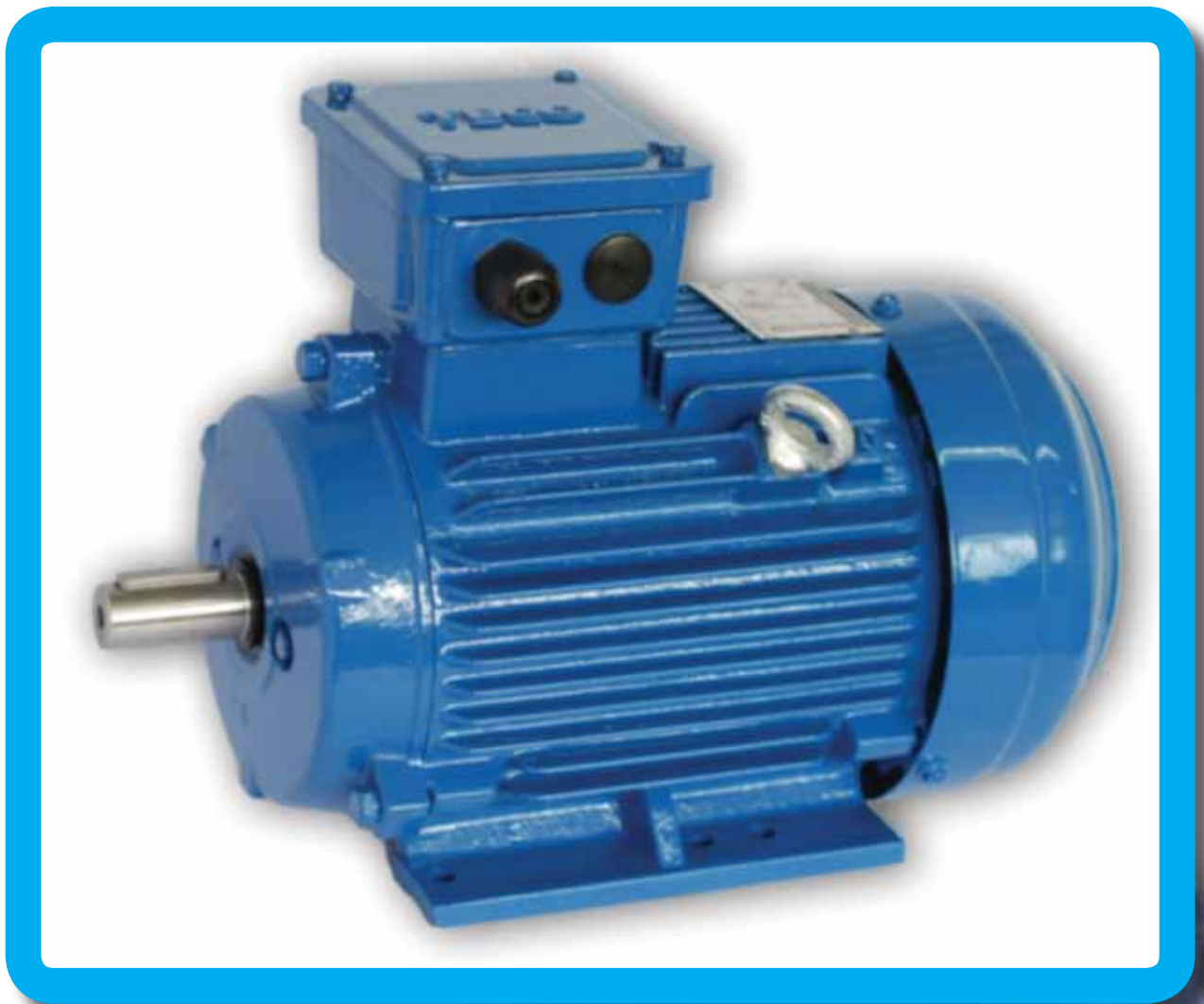

IE 2 Performance Data (2 Pole)

Motor Type AESV2S / AESU2S / AESV2S-LA

OUTPUT		FULL LOAD rpm	FRAME SIZE	EFFICIENCY			POWER FACTOR			CURRENT				TORQUE					APPROX. WEIGHT kg
kW	HP			FULL LOAD (%)	3/4 LOAD (%)	1/2 LOAD (%)	FULL LOAD (%)	3/4 LOAD (%)	1/2 LOAD (%)	FULL LOAD (A)			LRC (A)	FULL LOAD kg-m	LOCKED ROTOR %FLT	PULL-UP %FLT	BREAK-DOWN %FLT	ROTOR GD ² kg-m ²	
										VOLTAGE									
										380	400	415	400V						
0.75	1	2850	80M	77.4	78.0	76.3	85.5	78.5	66.0	1.72	1.64	1.58	9.0	0.256	215	180	280	0.005	16.5
1.1	1.5	2875	80M	79.6	80.0	78.3	85.5	79.0	67.0	2.46	2.33	2.25	17	0.372	255	200	305	0.007	19.5
1.5	2	2880	90S	81.3	81.8	80.3	86.5	80.5	69.0	3.24	3.08	2.97	24	0.507	260	245	325	0.011	24.0
2.2	3	2875	90L	83.2	84.3	83.4	87.5	82.0	70.5	4.59	4.36	4.20	35	0.745	285	240	335	0.014	28.0
3	4	2895	100L	84.6	85.9	85.7	88.0	83.0	73.0	6.12	5.82	5.61	49	1.008	245	225	310	0.022	38.0
3.7	5	2880	112M	85.5	86.5	85.4	90.0	87.0	79.0	7.31	6.94	6.69	59	1.250	240	210	320	0.038	47.5
4	5.5	2880	112M	85.8	86.9	86.6	91.0	88.0	81.0	7.78	7.39	7.13	63	1.351	235	205	315	0.042	47.5
5.5	7.5	2925	132S	87.0	87.2	86.2	86.0	82.5	74.5	11.2	10.6	10.2	82	1.830	240	180	300	0.063	66.0
7.5	10	2920	132S	88.1	88.3	87.8	82.5	77.5	68.0	15.7	14.9	14.4	98	2.499	250	230	275	0.075	72.5
11	15	2950	160M	89.4	89.3	88.1	90.5	87.5	80.5	20.7	19.6	18.9	172	3.628	230	180	305	0.154	110
15	20	2930	160M	90.3	91.0	91.2	93.5	92.5	89.0	27.0	25.6	24.7	225	4.981	245	165	280	0.192	120
18.5	25	2925	160L	90.9	91.5	91.7	93.0	91.5	88.0	33.2	31.6	30.4	290	6.154	260	185	310	0.237	135
22	30	2930	180M	91.3	91.2	90.5	91.5	90.0	85.5	40.0	38.0	36.6	295	7.306	215	185	300	0.283	175
30	40	2945	200L	92.0	92.2	91.3	90.5	89.5	86.0	54.7	52.0	50.1	440	9.912	210	150	300	0.521	245
37	50	2945	200L	92.5	92.9	92.7	91.5	90.5	87.5	66.4	63.1	60.8	585	12.22	175	130	260	0.663	275
45	60	2965	225MA	92.9	92.5	91.3	91.0	88.5	82.5	80.9	76.8	74.1	710	14.77	170	140	300	1.074	320
55	75	2970	250MA	93.2	93.2	92.6	92.5	91.5	88.0	96.9	92.1	88.8	730	18.02	165	150	300	1.343	430
75	100	2960	280SA	93.8	93.6	92.8	89.0	87.5	82.0	136	130	125	885	24.69	130	120	285	1.759	522
90	125	2970	280MA	94.1	93.9	92.8	87.5	86.0	76.0	166	158	152	1335	29.53	175	135	300	2.287	596
110	150	2975	315SA	94.3	94.1	93.0	88.0	85.0	76.5	201	191	184	1520	36.03	200	165	270	3.600	850
132	175	2975	315MA	94.6	94.3	93.4	89.5	88.0	83.0	237	225	217	1750	43.24	200	165	270	4.400	920
(160)	(215)	2975	315MA	94.8	94.5	93.5	91.0	89.5	84.5	282	268	258	2175	52.41	210	175	270	5.600	980
160	215	2975	315LA	94.8	94.5	93.5	91.0	89.5	84.5	282	268	258	2175	52.41	210	175	270	5.600	1010
200	270	2975	315LA	95.0	94.8	93.8	92.0	91.0	88.5	348	330	318	2620	65.51	210	175	260	7.200	1140
(220)	(300)	2972	315CA	95.0	94.6	93.5	91.5	90.0	86.0	385	365	352	2750	72.14	140	120	280	7.600	1420
220	300	2975	355MA	95.0	94.6	93.5	91.0	90.0	85.0	387	367	354	2750	72.06	130	110	280	8.100	1650
(250)	(335)	2972	315CA	95.0	94.6	93.4	92.0	91.0	88.0	435	413	398	3100	81.97	140	120	280	8.400	1540
250	335	2975	355MA	95.0	94.6	93.4	91.5	90.0	85.5	437	415	400	3100	81.89	140	120	280	12.40	1700
(315)	(420)	2975	315DA	95.0	94.8	94.0	92.5	91.5	89.0	545	517	499	3900	103.2	150	135	280	10.80	1760
315	420	2978	355LA	95.0	94.8	93.8	92.0	91.0	87.0	548	520	501	3900	103.1	140	120	280	14.40	2000
375	500	2978	355CA	95.3	95.0	94.4	91.0	90.0	86.0	657	624	602	4500	122.7	150	125	280	16.00	2400

Note:

1. The above are typical values based on test according to IEC 60045-2-1:2007. (DY)
2. Tolerance according to IEC 60034-1.
3. Breakdown & Locked rotor torques are show as average expected voltages
4. Efficiency, power factor, speed and torque are the same for other voltages.
Current values vary inversely with voltage
5. Output in () is for Optional Frame size upon request
6. Frame size 315C, 315D & 355C: only suitable for IM B3 and IM B5
7. Noise according to IEC 60034-9.
8. Data subject to change without prior notice.

IE 2 Performance Data (4 Pole)

Motor Type AESV2S / AESU2S / AESV2S-LA

OUTPUT		FULL LOAD rpm	FRAME SIZE	EFFICIENCY			POWER FACTOR			CURRENT				TORQUE					APPROX. WEIGHT kg
kW	HP			FULL LOAD (%)	3/4 LOAD (%)	1/2 LOAD (%)	FULL LOAD (%)	3/4 LOAD (%)	1/2 LOAD (%)	FULL LOAD (A)			LRC (A)	FULL LOAD kg-m	LOCKED ROTOR %FLT	PULL-UP %FLT	BREAK-DOWN %FLT	ROTOR GD ² kg-m ²	
										380	400	415							
0.55	0.75	1425	80M	78.1	78.0	75.1	72.5	62.0	47.5	1.48	1.40	1.35	8.0	0.376	290	260	305	0.010	17.5
0.75	1	1415	80M	79.6	79.5	76.9	73.5	63.5	49.5	1.95	1.85	1.78	11	0.516	300	295	325	0.013	20.5
1.1	1.5	1445	90S	81.4	81.4	78.9	76.0	67.0	53.0	2.70	2.57	2.47	19	0.741	270	205	325	0.017	25.0
1.5	2	1435	90L	82.8	83.7	82.6	81.0	73.0	59.5	3.40	3.23	3.11	23	1.017	250	180	300	0.022	27.5
2.2	3	1450	100L	84.3	85.0	84.1	81.5	74.0	61.0	4.87	4.62	4.45	33	1.476	210	170	300	0.041	37.0
3	4	1445	100L	85.5	85.9	84.8	82.0	75.0	62.5	6.50	6.18	5.95	44	2.020	210	170	300	0.050	40.0
3.7	5	1435	112M	86.3	87.0	87.0	86.5	83.0	74.0	7.53	7.15	6.90	59	2.509	220	150	290	0.076	50.0
4	5.5	1450	112M	86.6	87.6	87.5	85.0	80.5	71.0	8.26	7.84	7.56	58	2.684	220	200	300	0.083	53.0
5.5	7.5	1455	132S	87.7	88.7	88.6	85.5	80.5	70.0	11.1	10.6	10.2	81	3.678	255	210	305	0.123	70.5
7.5	10	1460	132M	88.7	89.6	89.5	84.0	78.5	67.0	15.3	14.5	14.0	112	4.998	275	200	305	0.142	82.0
11	15	1465	160M	89.8	90.6	90.7	86.5	83.0	74.5	21.5	20.4	19.7	160	7.306	220	180	300	0.296	115
15	20	1470	160L	90.6	91.3	91.2	86.5	82.5	73.5	29.1	27.6	26.6	220	9.929	220	185	300	0.427	140
18.5	25	1475	180M	91.2	91.7	91.6	85.5	83.0	76.5	36.0	34.2	33.0	230	12.20	200	185	300	0.654	180
22	30	1470	180L	91.6	92.4	92.2	85.5	83.5	77.5	42.7	40.5	39.1	270	14.56	195	155	250	0.770	200
30	40	1470	200L	92.3	92.9	92.9	87.5	84.5	77.0	56.4	53.6	51.7	420	19.86	230	180	300	1.217	255
37	50	1475	225SC	92.7	93.3	93.3	87.5	86.0	80.0	69.3	65.8	63.5	430	24.41	220	175	260	1.649	320
45	60	1480	225MC	93.1	93.3	92.9	86.0	82.5	75.0	85.4	81.1	78.2	580	29.58	210	170	300	1.979	355
55	75	1485	250MC	93.5	93.7	93.3	87.5	85.0	79.0	102	97.0	93.5	780	36.04	245	180	300	3.621	455
75	100	1480	280SB	94.0	94.0	93.2	87.0	84.0	77.5	139	132	128	1015	49.38	185	170	300	4.853	604
90	125	1480	280MB	94.2	94.0	93.2	85.5	82.5	75.5	170	161	155	1260	59.26	200	190	280	5.393	648
110	150	1484	315SB	94.5	94.5	93.8	88.5	86.0	79.0	200	190	183	1400	72.23	200	165	270	8.800	860
132	175	1484	315MB	94.7	94.7	94.0	88.5	86.0	79.0	239	227	219	1620	86.68	200	165	270	10.00	970
(160)	(215)	1485	315MB	94.9	94.9	94.2	88.5	87.0	80.0	289	275	265	2000	105.0	210	175	270	11.60	1020
160	215	1485	315LB	94.9	94.9	94.2	88.5	87.0	80.0	289	275	265	2000	105.0	210	175	270	11.60	1050
200	270	1485	315LB	95.1	95.1	94.6	89.0	87.5	82.0	359	341	329	2450	131.2	200	165	270	14.40	1240
(220)	(300)	1485	315CB	95.1	95.1	94.4	90.0	89.0	84.0	391	371	358	2800	144.4	210	175	260	22.00	1500
220	300	1485	355MB	95.1	95.1	94.4	87.0	83.5	74.5	404	384	370	2850	144.4	200	165	270	21.60	1650
(250)	(335)	1485	315CB	95.1	95.1	94.4	90.0	89.0	84.5	444	422	406	3100	164.1	210	175	260	24.00	1620
250	335	1486	355MB	95.1	95.1	94.4	88.0	85.5	78.5	454	431	416	3100	163.9	200	165	270	24.40	1700
(315)	(420)	1485	315DB	95.1	95.1	94.6	89.5	87.5	81.5	562	534	515	4100	206.7	210	175	260	26.40	1820
315	420	1488	355LB	95.1	95.1	94.6	88.5	85.5	78.5	569	540	521	3900	206.3	200	165	270	28.80	2000
375	500	1488	355CB	95.3	95.3	94.8	89.5	87.5	81.5	668	635	612	4450	245.6	200	165	270	34.40	2400

Note:

1. The above are typical values based on test according to IEC 60045-2-1:2007. (DY)
2. Tolerance according to IEC 60034-1.
3. Breakdown & Locked rotor torques are show as average expected voltages
4. Efficiency, power factor, speed and torque are the same for other voltages.
Current values vary inversely with voltage
5. Output in () is for Optional Frame size upon request
6. Frame size 315C, 315D & 355C: only suitable for IM B3 and IM B5
7. Noise according to IEC 60034-9.
8. Data subject to change without prior notice.

IE 2 Performance Data (6 Pole)

Motor Type AESV2S / AESU2S / AESV2S-LA

OUTPUT		FULL LOAD rpm	FRAME SIZE	EFFICIENCY			POWER FACTOR			CURRENT				TORQUE					APPROX. WEIGHT kg
kW	HP			FULL LOAD (%)	3/4 LOAD (%)	1/2 LOAD (%)	FULL LOAD (%)	3/4 LOAD (%)	1/2 LOAD (%)	FULL LOAD (A)			LRC (A)	FULL LOAD kg-m	LOCKED ROTOR %FLT	PULL-UP %FLT	BREAK-DOWN %FLT	ROTOR GD ² kg-m ²	
										VOLTAGE									
										380	400	415	400V						
0.55	0.75	900	80M	73.1	68.8	64.9	67.0	57.0	44.0	1.71	1.62	1.56	7.0	0.595	225	220	250	0.012	18.0
0.75	1	935	90S	75.9	76.4	73.9	69.5	60.0	46.5	2.16	2.05	1.98	10	0.780	210	185	260	0.019	26.0
1.1	1.5	930	90L	78.1	78.8	76.9	71.5	62.0	48.5	2.99	2.84	2.74	14	1.151	215	190	260	0.026	30.0
1.5	2	950	100L	79.8	80.5	78.8	70.5	61.5	48.5	4.05	3.85	3.71	19	1.536	170	140	240	0.048	39.0
2.2	3	950	112M	81.8	82.4	81.1	75.0	66.5	53.0	5.45	5.18	4.99	34	2.253	280	255	300	0.071	47.0
3	4	960	132S	83.3	84.1	83.2	78.0	71.0	58.0	7.02	6.66	6.42	37	3.041	190	165	300	0.103	59.0
3.7	5	965	132M	84.3	84.3	82.8	76.0	68.5	55.0	8.78	8.34	8.04	61	3.731	180	180	270	0.131	63.0
4	5.5	960	132M	84.6	85.6	85.1	79.0	72.5	60.0	9.09	8.64	8.33	53	4.054	210	180	300	0.131	69.0
5.5	7.5	960	132M	86.0	86.9	86.5	79.5	72.5	60.5	12.2	11.6	11.2	78	5.574	230	195	300	0.188	82.0
7.5	10	960	160M	87.2	88.2	87.7	82.0	77.0	66.5	15.9	15.1	14.6	105	7.602	210	195	260	0.363	110
11	15	965	160L	88.7	89.2	88.6	81.5	76.0	65.0	23.1	22.0	21.2	170	11.09	245	205	300	0.558	140
15	20	975	180L	89.7	90.4	90.2	82.5	77.5	67.5	30.8	29.3	28.2	220	14.97	210	195	300	1.337	203
18.5	25	975	200L	90.4	91.0	90.9	79.5	75.0	65.5	39.1	37.2	35.8	260	18.46	215	195	300	1.604	250
22	30	980	200L	90.9	91.4	91.8	81.0	77.5	68.5	45.4	43.1	41.6	300	21.84	210	180	255	1.912	270
30	40	980	225MC	91.7	92.4	92.2	86.0	83.0	76.0	57.8	54.9	52.9	365	29.79	210	190	285	2.442	335
37	50	980	250MC	92.2	92.3	91.7	86.5	83.0	74.0	70.5	67.0	64.5	455	36.74	210	185	275	3.373	410
45	60	985	280SB	92.7	92.5	91.3	80.5	75.0	64.5	91.6	87.0	83.9	600	44.52	200	185	300	5.290	542
55	75	985	280MB	93.1	93.0	92.1	82.5	78.0	68.0	109	103	99.6	700	54.41	195	185	295	6.492	610
75	100	985	315SB	93.7	93.7	92.8	84.0	80.0	70.0	145	138	133	850	74.20	200	165	240	10.80	850
90	125	987	315MB	94.0	94.0	93.1	84.0	81.0	71.0	173	165	159	1070	88.86	200	165	240	12.80	900
(110)	(150)	988	315MB	94.3	94.3	93.7	85.0	82.0	73.0	209	198	191	1370	108.5	200	165	250	16.40	1000
110	150	988	315LB	94.3	94.3	93.7	85.0	82.0	73.0	209	198	191	1370	108.5	200	165	250	16.40	1030
132	175	988	315LB	94.6	94.6	94.0	85.0	82.0	73.0	249	237	228	1500	130.2	200	165	250	18.40	1150
(160)	(215)	988	315LB	94.8	94.8	94.0	85.0	82.0	74.0	302	287	276	1880	157.8	210	175	250	23.20	1300
160	215	988	355MB	94.8	94.8	94.2	85.5	82.0	73.0	300	285	275	2040	157.8	200	165	250	31.60	1650
(200)	(270)	988	315CB	95.0	95.0	94.2	86.0	85.5	82.0	372	353	341	2400	197.3	200	165	250	33.60	1720
200	270	988	355MB	95.0	95.0	94.6	86.0	83.5	76.0	372	353	341	2400	197.3	200	165	250	35.20	1800
(220)	(300)	988	315CB	95.0	95.0	94.4	86.5	84.5	78.0	407	386	372	2750	217.0	200	165	250	36.40	1800
220	300	988	355MB	95.0	95.0	94.6	86.0	83.0	75.5	409	389	375	2750	217.0	200	165	250	39.60	1900
(250)	(335)	988	315DB	95.0	95.0	94.6	86.5	84.0	77.0	462	439	423	3000	246.6	200	165	250	42.00	1900
250	335	988	355LB	95.0	95.0	94.6	86.0	83.0	75.5	465	442	426	3060	246.6	200	165	250	44.40	2080
315	420	988	355CB	95.2	95.2	94.8	87.0	85.0	78.0	578	549	529	3700	310.7	200	165	250	55.60	2650

Note:

1. The above are typical values based on test according to IEC 60045-2-1:2007. (DY)
2. Tolerance according to IEC 60034-1.
3. Breakdown & Locked rotor torques are show as average expected voltages
4. Efficiency, power factor, speed and torque are the same for other voltages.
Current values vary inversely with voltage
5. Output in () is for Optional Frame size upon request
6. Frame size 315C, 315D & 355C: only suitable for IM B3 and IM B5
7. Noise according to IEC 60034-9.
8. Data subject to change without prior notice.

IE 3 Performance Data



IE 3 Performance Data (2 Pole)

Motor Type AESV3S / AESU3S / AESV3S-LA

OUTPUT		FULL LOAD rpm	FRAME SIZE	EFFICIENCY			POWER FACTOR			CURRENT				TORQUE					APPROX. WEIGHT kg
kW	HP			FULL LOAD (%)	3/4 LOAD (%)	1/2 LOAD (%)	FULL LOAD (%)	3/4 LOAD (%)	1/2 LOAD (%)	FULL LOAD (A)			LRC (A)	FULL LOAD kg-m	LOCKED ROTOR %FLT	PULL-UP %FLT	BREAK-DOWN %FLT	ROTOR GD ² kg-m ²	
										380	400	415							
0.75	1	2875	80M	80.7	78.3	75.1	84.5	78.0	66.5	1.67	1.59	1.53	12	0.254	280	275	335	0.006	18.0
1.1	1.5	2870	80M	82.7	83.0	81.3	85.0	78.5	66.5	2.38	2.26	2.18	18	0.373	300	295	350	0.007	19.5
1.5	2	2850	90S	84.2	85.4	85.8	90.5	87.0	78.0	2.99	2.84	2.74	22	0.512	220	210	300	0.012	25.5
2.2	3	2860	90L	85.9	86.7	86.8	89.5	85.0	75.5	4.35	4.13	3.98	35	0.748	245	235	315	0.014	29.0
3	4	2855	100L	87.1	88.3	88.4	90.0	86.5	78.5	5.81	5.52	5.32	48	1.022	325	310	355	0.025	41.5
3.7	5	2870	112M	87.8	88.2	88.0	90.5	87.5	80.0	7.07	6.72	6.48	60	1.254	290	270	345	0.046	51.5
4	5.5	2875	112M	88.1	89.0	88.9	91.0	87.5	80.0	7.58	7.20	6.94	69	1.354	270	250	360	0.046	51.5
5.5	7.5	2930	132S	89.2	89.8	89.5	88.5	86.0	79.5	10.6	10.1	9.69	80	1.826	210	205	340	0.075	73.0
7.5	10	2920	132S	90.1	90.9	90.8	87.0	84.5	77.5	14.5	13.8	13.3	100	2.499	210	195	315	0.081	76.0
11	15	2935	160M	91.2	92.0	92.0	90.0	89.0	83.5	20.4	19.3	18.6	150	3.647	230	185	300	0.183	130
15	20	2935	160M	91.9	92.0	92.0	89.0	85.5	77.5	27.9	26.5	25.5	230	4.973	275	230	330	0.205	130
18.5	25	2930	160L	92.4	93.0	93.0	90.0	89.5	84.0	33.8	32.1	30.9	260	6.144	245	200	300	0.237	140
22	30	2940	180M	92.7	92.7	92.5	87.0	85.0	77.0	41.4	39.4	38.0	300	7.281	225	180	300	0.283	180
30	40	2950	200L	93.3	93.5	92.5	90.0	90.0	86.5	54.3	51.6	49.7	400	9.895	200	145	300	0.602	265
37	50	2955	200L	93.7	94.5	94.0	91.0	90.5	87.0	65.9	62.6	60.4	510	12.18	210	145	300	0.753	300
45	60	2960	225MA	94.0	94.0	93.5	91.0	91.0	88.0	79.9	75.9	73.2	615	14.79	170	140	300	1.187	340
55	75	2970	250MA	94.3	94.5	94.0	91.5	90.0	86.5	96.8	92.0	88.7	735	18.02	165	130	315	1.544	465
75	100	2970	280SA	94.7	94.6	93.6	81.5	77.0	66.5	148	140	135	1090	24.61	155	135	300	1.935	553
90	125	2970	280MA	95.0	95.0	94.0	90.5	90.0	82.5	159	151	146	1255	29.53	150	135	285	2.463	620
110	150	2972	315SA	95.2	95.0	94.0	90.0	89.0	85.0	195	185	179	1400	36.07	200	165	240	4.000	900
132	175	2972	315MA	95.4	95.3	94.5	90.5	89.5	87.0	232	221	213	1650	43.28	200	165	240	4.800	960
(160)	(215)	2975	315MA	95.6	95.5	94.8	91.0	90.0	86.5	279	265	256	2140	52.41	200	165	250	5.200	1000
160	215	2975	315LA	95.6	95.5	94.8	91.0	90.0	86.5	279	265	256	2140	52.41	200	165	250	5.200	1030
200	270	2975	315LA	95.8	95.8	95.2	91.5	90.5	87.5	347	329	317	2450	65.51	200	165	250	7.200	1160
(220)	(300)	2975	315CA	95.8	95.6	95.0	90.0	88.5	83.5	388	368	355	2750	72.06	180	150	230	8.400	1520
220	300	2975	355MA	95.8	95.4	94.2	91.5	90.0	85.0	381	362	349	2810	72.06	140	120	280	12.40	1750
(250)	(335)	2975	315CA	95.8	95.6	95.0	91.0	89.5	85.5	436	414	399	3000	81.89	180	150	235	10.00	1660
250	335	2975	355MA	95.8	95.5	94.5	92.0	91.0	87.0	431	409	395	3000	81.89	140	120	280	13.60	1820
(315)	(420)	2975	315DA	95.8	95.6	95.0	91.0	90.0	86.0	549	522	503	3900	103.2	180	150	240	11.20	1800
315	420	2978	355LA	95.8	95.5	94.5	92.0	91.0	87.0	543	516	497	3900	103.1	140	120	280	14.40	2150
375	500	2978	355CA	95.8	95.6	94.7	92.5	91.0	87.0	643	611	589	4500	122.7	150	125	280	16.00	2500

Note:

1. The above are typical values based on test according to IEC 60045-2-1:2007. (DY)
2. Tolerance according to IEC 60034-1.
3. Breakdown & Locked rotor torques are show as average expected voltages
4. Efficiency, power factor, speed and torque are the same for other voltages.
Current values vary inversely with voltage
5. Output in () is for Optional Frame size upon request
6. Frame size 315C, 315D & 355C: only suitable for IM B3 and IM B5
7. Noise according to IEC 60034-9.
8. Data subject to change without prior notice.

IE 3 Performance Data (4 Pole)

Motor Type AESV3S / AESU3S / AESV3S-LA

OUTPUT		FULL LOAD rpm	FRAME SIZE	EFFICIENCY			POWER FACTOR			CURRENT				TORQUE					APPROX. WEIGHT kg
kW	HP			FULL LOAD (%)	3/4 LOAD (%)	1/2 LOAD (%)	FULL LOAD (%)	3/4 LOAD (%)	1/2 LOAD (%)	FULL LOAD (A)			LRC (A)	FULL LOAD kg-m	LOCKED ROTOR %FLT	PULL-UP %FLT	BREAK-DOWN %FLT	ROTOR GD ² kg-m ²	
										380	400	415							
0.55	0.75	1430	80M	80.8	77.9	74.7	69.0	58.5	44.5	1.50	1.42	1.37	9.0	0.374	300	270	320	0.010	17.5
0.75	1	1410	80M	82.5	81.8	79.7	73.5	64.0	50.0	1.88	1.79	1.72	11	0.518	315	290	335	0.013	20.5
1.1	1.5	1430	90S	84.1	84.4	83.2	79.5	71.5	57.5	2.50	2.37	2.29	17	0.748	255	205	300	0.019	26.5
1.5	2	1435	90L	85.3	84.1	82.2	75.0	65.5	51.5	3.56	3.38	3.26	26	1.017	300	235	335	0.023	28.5
2.2	3	1450	100L	86.7	87.3	86.9	81.0	73.5	60.5	4.76	4.52	4.36	33	1.476	210	160	300	0.045	39.5
3	4	1455	100L	87.7	87.7	86.2	78.0	70.5	57.5	6.66	6.33	6.10	49	2.006	250	240	335	0.052	42.0
3.7	5	1445	112M	88.4	89.1	88.8	82.0	77.0	66.0	7.76	7.37	7.10	60	2.491	235	200	305	0.083	53.0
4	5.5	1445	112M	88.6	88.4	87.9	82.0	76.5	65.5	8.37	7.95	7.66	57	2.693	245	205	300	0.083	53.0
5.5	7.5	1455	132S	89.6	90.4	90.3	85.0	80.5	70.0	11.0	10.4	10.0	77	3.678	240	200	300	0.132	75.5
7.5	10	1460	132M	90.4	90.8	90.4	84.5	79.5	69.0	14.9	14.2	13.7	110	4.998	270	225	330	0.172	93.0
11	15	1460	160M	91.4	92.0	91.5	84.0	80.0	70.0	21.8	20.7	19.9	160	7.331	230	185	300	0.366	130
15	20	1460	160L	92.1	92.5	92.5	84.5	81.0	71.0	29.3	27.8	26.8	225	9.997	250	195	300	0.460	150
18.5	25	1475	180M	92.6	94.0	93.0	81.5	77.0	69.5	37.2	35.4	34.1	270	12.20	215	160	280	0.704	195
22	30	1475	180L	93.0	93.5	93.0	81.0	77.0	71.0	44.4	42.2	40.6	315	14.51	210	145	275	0.789	205
30	40	1470	200L	93.6	94.5	94.5	86.0	84.5	77.0	56.6	53.8	51.8	445	19.86	250	205	300	1.451	285
37	50	1480	225SC	93.9	94.5	94.0	85.5	82.0	73.0	70.0	66.5	64.1	505	24.33	210	175	300	1.896	350
45	60	1480	225MC	94.2	94.5	94.0	84.5	79.5	70.0	85.9	81.6	78.6	600	29.58	210	175	300	1.979	360
55	75	1485	250MC	94.6	94.6	94.0	87.5	84.5	77.0	101	95.9	92.4	750	36.04	210	185	295	3.911	480
75	100	1480	280SB	95.0	95.0	94.5	85.0	82.0	73.0	141	134	129	1030	49.38	160	150	300	5.033	621
90	125	1480	280MB	95.2	95.2	94.7	84.0	80.0	70.5	171	162	157	1260	59.26	175	165	300	6.112	706
110	150	1484	315SB	95.4	95.4	95.0	89.0	87.0	80.5	197	187	180	1400	72.23	200	165	270	9.200	920
132	175	1484	315MB	95.6	95.6	95.2	89.0	87.5	82.0	236	224	216	1650	86.68	200	165	270	10.40	1000
(160)	(215)	1485	315MB	95.8	95.8	95.5	89.5	88.0	82.0	284	269	260	2000	105.0	200	165	260	11.60	1040
160	215	1485	315LB	95.8	95.8	95.5	89.5	88.0	82.0	284	269	260	2000	105.0	200	165	260	11.60	1070
200	270	1485	315LB	96.0	96.0	95.8	90.0	89.0	84.5	352	334	322	2500	131.2	200	165	260	14.00	1260
(220)	(300)	1488	315CB	96.0	95.9	95.2	86.0	82.0	72.0	405	385	371	2800	144.1	200	165	260	24.00	1550
220	300	1487	355MB	96.0	96.0	95.4	88.8	86.2	79.0	392	372	359	2750	144.2	180	150	260	22.80	1750
(250)	(335)	1488	315CB	96.0	96.0	95.4	86.5	83.5	75.0	457	435	419	3100	163.7	200	165	260	26.00	1700
250	335	1487	355MB	96.0	95.8	95.2	88.8	86.2	78.2	446	423	408	3280	163.8	200	165	270	27.20	1820
(315)	(420)	1488	315DB	96.0	96.0	95.5	86.5	83.5	75.0	576	548	528	3900	206.3	200	165	260	29.20	1940
315	420	1488	355LB	96.0	96.0	95.5	89.5	87.5	81.0	557	529	510	3900	206.3	200	165	270	31.20	2150
375	500	1488	355CB	96.0	96.0	95.5	89.5	87.0	81.0	663	630	607	4570	245.6	200	165	270	35.60	2500

Note:

1. The above are typical values based on test according to IEC 60045-2-1:2007. (DY)
2. Tolerance according to IEC 60034-1.
3. Breakdown & Locked rotor torques are show as average expected voltages
4. Efficiency, power factor, speed and torque are the same for other voltages.
Current values vary inversely with voltage
5. Output in () is for Optional Frame size upon request
6. Frame size 315C, 315D & 355C: only suitable for IM B3 and IM B5
7. Noise according to IEC 60034-9.
8. Data subject to change without prior notice.

IE 3 Performance Data (6 Pole)

Motor Type AESV3S / AESU3S / AESV3S-LA

OUTPUT		FULL LOAD rpm	FRAME SIZE	EFFICIENCY			POWER FACTOR			CURRENT				TORQUE					APPROX. WEIGHT kg
kW	HP			FULL LOAD (%)	3/4 LOAD (%)	1/2 LOAD (%)	FULL LOAD (%)	3/4 LOAD (%)	1/2 LOAD (%)	FULL LOAD (A)			LRC (A)	FULL LOAD kg-m	LOCKED ROTOR %FLT	PULL-UP %FLT	BREAK-DOWN %FLT	ROTOR GD ² kg-m ²	
										VOLTAGE									
										380	400	415							
0.55	0.75	905	80M	77.2	69.7	66.2	69.0	58.0	44.5	1.57	1.49	1.44	6.0	0.591	210	195	250	0.012	19.5
0.75	1	935	90S	78.9	80.6	79.4	71.0	62.5	49.0	2.03	1.93	1.86	9.0	0.780	210	190	250	0.022	28.0
1.1	1.5	930	90L	81.0	81.2	80.5	72.0	63.5	50.0	2.87	2.72	2.62	13	1.151	210	185	240	0.026	30.5
1.5	2	950	100L	82.5	82.9	81.5	72.5	65.0	52.0	3.81	3.62	3.49	18	1.536	210	175	250	0.058	43.5
2.2	3	960	112M	84.3	84.3	82.2	67.0	59.0	47.0	5.92	5.62	5.42	29	2.230	190	180	280	0.083	53.5
3	4	970	132S	85.6	86.1	85.1	76.0	69.0	58.5	7.01	6.66	6.42	41	3.009	195	170	300	0.137	75.0
3.7	5	965	132M	86.5	87.5	87.0	77.0	70.0	58.0	8.44	8.02	7.73	56	3.731	200	185	275	0.143	77.0
4	5.5	970	132M	86.8	87.0	85.6	77.0	70.0	57.5	9.09	8.64	8.33	58	4.012	200	185	310	0.182	84.0
5.5	7.5	970	132M	88.0	88.5	87.6	79.5	72.5	60.0	11.9	11.3	10.9	88	5.517	210	205	300	0.216	91.0
7.5	10	970	160M	89.1	90.0	89.0	79.0	73.0	61.0	16.2	15.4	14.8	110	7.523	235	210	300	0.483	135
11	15	970	160L	90.3	91.0	90.5	78.0	72.0	60.5	23.7	22.5	21.7	170	11.03	295	255	300	0.628	150
15	20	970	180L	91.2	92.0	92.0	82.0	78.0	68.0	30.5	29.0	27.9	200	15.05	215	165	255	1.337	205
18.5	25	975	200L	91.7	92.5	92.5	80.5	76.0	66.5	38.1	36.2	34.9	260	18.46	220	185	265	1.829	270
22	30	975	200L	92.2	93.0	93.5	81.5	77.0	68.0	44.5	42.3	40.7	305	21.95	210	185	265	2.078	290
30	40	980	225MC	92.9	93.5	93.5	83.5	80.0	76.5	58.8	55.8	53.8	335	29.79	210	160	240	3.023	385
37	50	980	250MC	93.3	94.0	94.0	85.0	81.5	75.0	70.9	67.3	64.9	490	36.74	230	200	280	4.194	460
45	60	985	280SB	93.7	93.7	93.0	81.5	77.5	67.5	89.5	85.1	82.0	587	44.52	185	175	285	5.530	561
55	75	985	280MB	94.1	94.1	93.5	83.0	80.0	71.0	107	102	98.0	700	54.41	185	175	300	6.733	635
75	100	987	315SB	94.6	94.6	94.1	85.5	82.5	74.5	141	134	129	930	74.05	200	165	240	12.80	900
90	125	987	315MB	94.9	94.9	94.5	85.5	83.0	75.5	169	160	154	1200	88.86	200	165	240	15.20	960
(110)	(150)	988	315MB	95.1	95.1	94.7	85.5	83.0	75.5	206	195	188	1400	108.5	200	165	240	18.40	1060
110	150	988	315LB	95.1	95.1	94.7	85.5	83.0	75.5	206	195	188	1400	108.5	200	165	240	18.40	1090
132	175	988	315LB	95.4	95.4	95.0	85.5	83.0	75.5	246	234	225	1650	130.2	200	165	240	20.40	1250
(160)	(215)	988	315LB	95.6	95.6	95.2	85.0	82.0	74.0	299	284	274	2000	157.8	200	165	250	23.20	1320
160	215	988	355MB	95.6	95.6	95.2	85.5	82.0	73.0	297	283	272	2000	157.8	170	145	250	33.20	1750
(200)	(270)	988	315CB	95.8	95.8	95.2	86.0	83.0	74.5	369	350	338	2500	197.3	170	145	250	33.20	1800
200	270	988	355MB	95.8	95.8	95.4	86.0	82.5	74.0	369	350	338	2400	197.3	170	145	250	40.40	1950
(220)	(300)	988	315CB	95.8	95.8	95.4	86.5	84.0	76.0	403	383	369	2800	217.0	170	145	250	37.60	1900
220	300	988	355MB	95.8	95.8	95.5	86.5	83.5	76.0	403	383	369	2700	217.0	170	145	250	44.00	2020
(250)	(335)	988	315DB	95.8	95.8	95.4	86.5	83.5	75.0	458	435	420	3250	246.6	170	145	250	42.00	1940
250	335	988	355LB	95.8	95.8	95.5	86.8	84.0	76.5	457	434	418	3060	246.6	170	145	250	49.60	2200
315	420	988	355CB	95.8	95.8	95.5	87.0	85.0	78.0	574	546	526	3700	310.7	170	145	250	60.40	2800

Note:

1. The above are typical values based on test according to IEC 60045-2-1:2007. (DY)
2. Tolerance according to IEC 60034-1.
3. Breakdown & Locked rotor torques are show as average expected voltages
4. Efficiency, power factor, speed and torque are the same for other voltages.
Current values vary inversely with voltage
5. Output in () is for Optional Frame size upon request
6. Frame size 315C, 315D & 355C: only suitable for IM B3 and IM B5
7. Noise according to IEC 60034-9.
8. Data subject to change without prior notice.

B3 Outline Dimension

Foot Mounted(B3)

Motor Type: AESV1S, AESV2S, AESV3S

Frame Size: 80M to 225M

B3

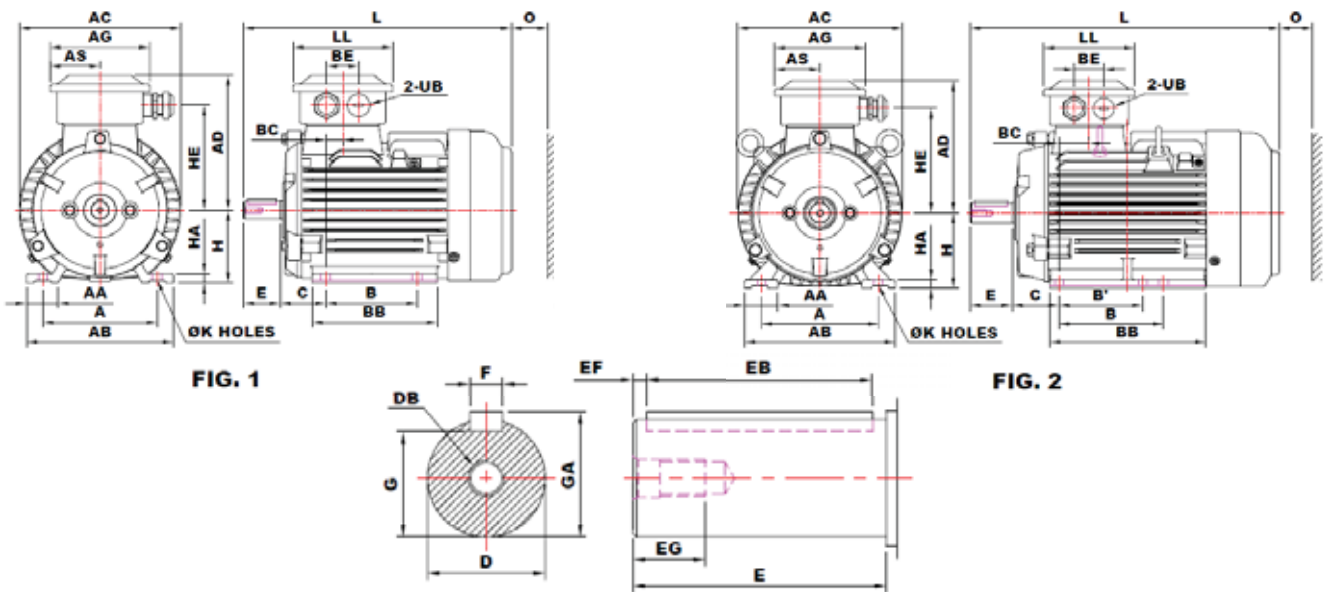

Output (kW)				FRAME SIZE	FIG. NO	A	AA	AB	AC	AD	AG	AS	B	B'	BA	BA'	BB	BC	BE	C
2P	4P	6P	8P																	
0.75 1.1	0.55 0.75	0.55	0.18	80M	1	125	34.5	161	177	148	109	54.5	100	---	---	---	137	18.5	35	50
1.5	1.1	0.75	0.37	90S	2	140	40	180	197	158	109	54.5	100	---	---	---	161	36	35	56
2.2	1.5	1.1	0.55	90L		140	40	180	197	158	109	54.5	125	100	---	---	186	36	35	56
3	2.2 3	1.5	0.75 1.1	100L		160	40	200	219	185.5	125	62.5	140	---	---	---	181	21	40	63
3.7 4	3.7 4	2.2	1.5	112M		190	45	235	235	193	125	62.5	140	---	---	---	186	28	40	70
5.5 7.5	5.5	3	2.2	132S		216	57	263	273	210.5	125	62.5	140	---	---	---	184	6	40	89
---	7.5	3.7 4 5.5	3	132M		216	57	263	273	210.5	125	62.5	178	140	---	---	222	6	40	89
11 15	11	7.5	3.7 4 5.5	160M	3	254	60	300	317	240.5	166	83	210	---	57.5	57.5	256	47	60	108
18.5	15	11	7.5	160L		254	60	300	317	240.5	166	83	254	210	57.5	101.5	300	47	60	108
22	18.5	---	---	180M		279	65	330	354	266.5	166	83	241	---	62	62	292	39	60	121
---	22	15	11	180L		279	65	330	354	266.5	166	83	279	241	62	100	330	39	60	121
30 37	30	18.5 22	15	200L	4	318	70	378	398	332	231	110.5	305	---	76	76	365	60	106	133
---	37	---	18.5	225SC		356	75	431	449	358	231	110.5	286	---	90	90	350	37.5	106	149
45	---	---	---	225MA		356	75	431	449	358	231	110.5	311	286	90	115	375	37.5	106	149
---	45	30	22	225MC		356	75	431	449	358	231	110.5	311	286	90	115	375	37.5	106	149

Note:

1. All dimensions are in mm.
2. Pre-packed shielded ball bearing for frame size 80M to 225M
3. Dual Eye-bolts provided for frame 90S to 355C
4. Data are subject to change without prior notice

B3

B3 Outline Dimension

Foot Mounted(B3)
Motor Type: AESV1S, AESV2S, AESV3S
Frame Size: 80M to 225M

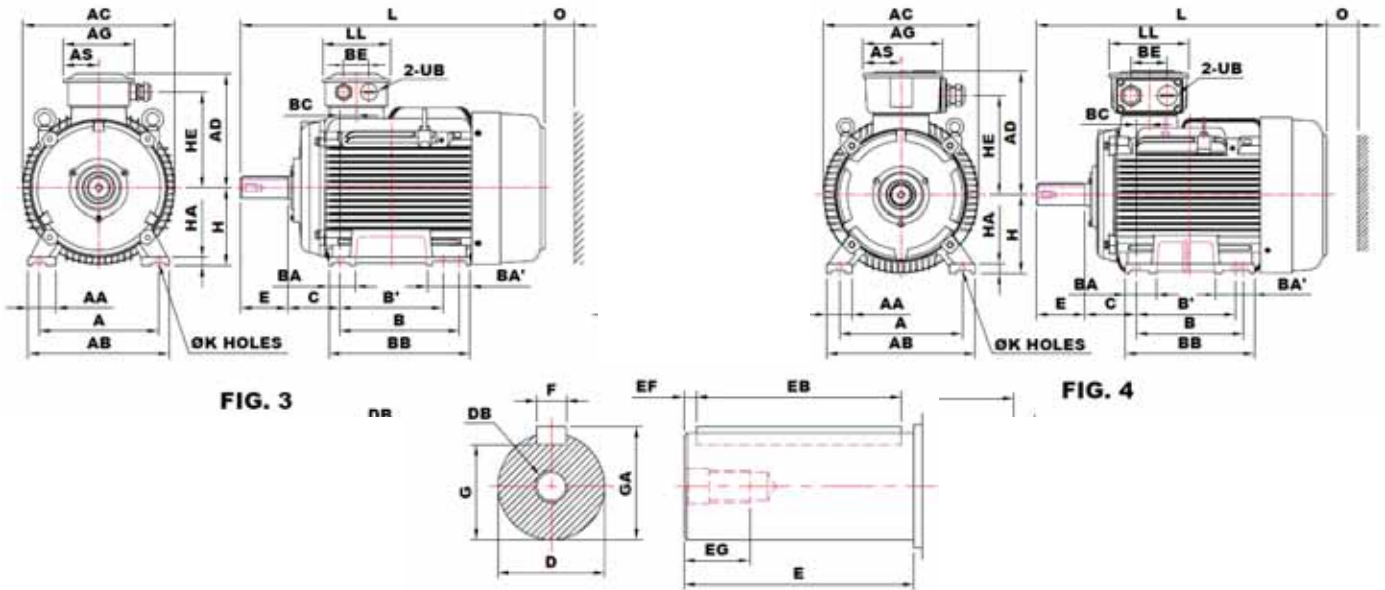

FIG. 3

FIG. 4

FRAME SIZE	H	HA	HE	K	L	LL	O	UB	SHAFT EXTENSION								BEARING		
									D	E	EB	EF	EG	F	G	GA	DB	DRIVE END	OPPOSITE DRIVE END
80M	80	10	115	10	293	109	40	M20x1.5	19	40	32	4	16	6	15.5	21.5	M6	6204ZZC3	6204ZZC3
90S	90	10	125	10	344.5	109	40	M20x1.5	24	50	40	5	19	8	20	27	M8	6205ZZC3	6205ZZC3
90L	90	10	125	10	369.5	109	40	M20x1.5	24	50	40	5	19	8	20	27	M8		
100L	100	12	146	12	392	125	50	M25X1.5	28	60	50	5	22	8	24	31	M10	6206ZZC3	6206ZZC3
112M	112	13	153.5	12	412.5	125	50	M25X1.5	28	60	50	5	22	8	24	31	M10	6306ZZC3	6306ZZC3
132S	132	16	171	12	466	125	50	M25x1.5	38	80	70	5	28	10	33	41	M12	6308ZZC3	6306ZZC3
132M	132	16	171	12	504	125	50	M25x1.5	38	80	70	5	28	10	33	41	M12		
160M	160	18	198	14.5	608	158	60	M32x1.5	42	110	100	5	36	12	37	45	M16	6309ZZC3	6307ZZC3
160L	160	18	198	14.5	652	158	60	M32x1.5	42	110	100	5	36	12	37	45	M16		
180M	180	20	224	14.5	672	158	70	M32x1.5	48	110	100	5	36	14	42.5	51.5	M16	6311ZZC3	6310ZZC3
180L	180	20	224	14.5	710	158	70	M32x1.5	48	110	100	5	36	14	42.5	51.5	M16		
200L	200	24	262	18.5	770	231	80	M50x1.5	55	110	100	5	42	16	49	59	M20	6312ZZC3	6212ZZC3
225SC	225	28	288	18.5	816	231	90	M50x1.5	60	140	125	7.5	42	18	53	64	M20	6313ZZC3	6213ZZC3
225MA	225	28	288	18.5	811	231	90	M50x1.5	55	110	100	5	42	16	49	59	M20	6312ZZC3	6212ZZC3
225MC	225	28	288	18.5	841	231	90	M50x1.5	60	140	125	7.5	42	18	53	64	M20	6313ZZC3	6213ZZC3

Note:

- All dimensions are in mm.
- Tolerance of shaft end diameter D: 1) $\varnothing 19\sim\varnothing 28:j6$, 2) $\varnothing 38\sim\varnothing 48:k6$, 3) $\varnothing 55\sim\varnothing 65:m6$
- Tolerance of shaft center high H : +0, -0.5
- Data are subject to change without prior notice

B3 Outline Dimension

Foot Mounted(B3)

Motor Type: AESV1S, AESV2S, AESV3S

Frame Size: 250 M to 355C

B3

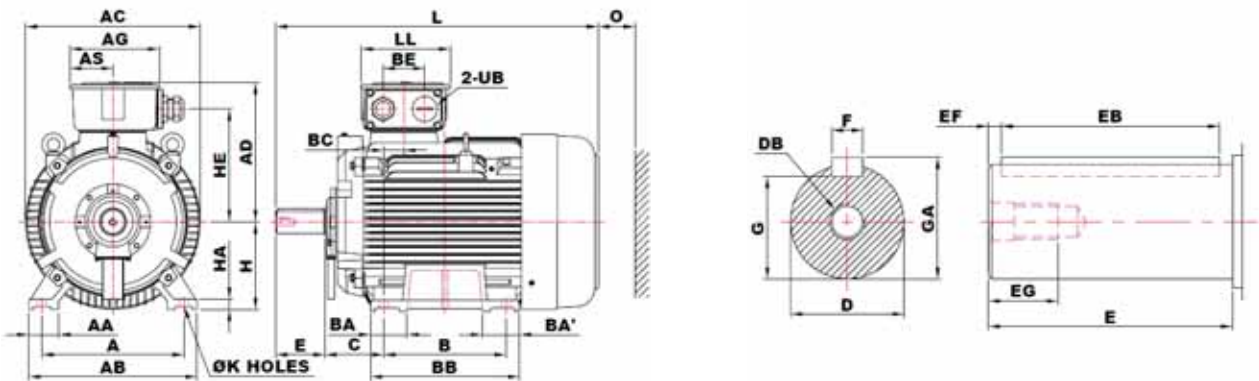

FIG. 5

Output (kW)				FRAME SIZE	FIG. NO	A	AA	AB	AC	AD	AG	AS	B	B'	BA	BA'	BB	BC	BE	C
2P	4P	6P	8P																	
55	---	---	---	250MA	5	406	85	480	499	400	255	122.5	349	---	105	105	425	57.5	119	168
---	55	37	30	250MC		406	85	480	499	400	255	122.5	349	---	105	105	425	57.5	119	168
75	---	---	---	280SA	5	457	110	560	546	433	255	122.5	368	---	110	110	445	48	119	190
---	75	45	37	280SB		457	110	560	546	433	255	122.5	368	---	110	110	445	48	119	190
90	---	---	---	280MA	5	457	110	560	546	433	255	122.5	419	---	130	137	495	48	119	190
---	90	55	45	280MB		457	110	560	546	433	255	122.5	419	---	130	137	495	48	119	190
110	---	---	---	315SA	5	508	115	615	620	527.5	336	163	406	---	210	210	620	53	140	216
---	110	75	55	315SB		508	115	615	620	527.5	336	163	406	---	210	210	620	53	140	216
132 (160)	---	---	---	315MA	5	508	115	615	620	527.5	336	163	457	---	240	240	670	53	140	216
---	132 (160)	90 (110)	75	315MB		508	115	615	620	527.5	336	163	457	---	240	240	670	53	140	216
160 200	---	---	---	315LA	5	508	130	630	620	527.5	336	163	508	---	230	230	770	53	140	216
---	160 200	110 132 (160)	90 110	315LB		508	130	630	620	527.5	336	163	508	---	230	230	770	53	140	216
(220) (250)	---	---	---	315CA	6	508	150	650	682	590	412	189	710	---	335	335	900	68	180	216
---	(220) (250)	(200) (220)	(132) (160)	315CB		508	150	650	682	590	412	189	710	---	335	335	900	68	180	216
(315)	---	---	---	315DA	6	508	150	650	682	590	412	189	900	---	180	250	1060	68	180	216
---	(315)	(250)	(200) (220)	315DB		508	150	650	682	590	412	189	900	---	180	250	1060	68	180	216
220 250	---	---	---	355MA	6	610	150	750	810	645	412	189	---	560	330	330	910	48	180	254
---	220 250	160 200 220	132 160	355MB		610	150	750	810	645	412	189	---	560	330	330	910	48	180	254
315	---	---	---	355LA	6	610	150	750	810	645	412	189	630	---	330	330	910	48	180	254
---	315	250	200 220	355LB		610	150	750	810	645	412	189	630	---	330	330	910	48	180	254
375	---	---	---	355CA	6	610	150	750	810	645	412	189	710	---	390	390	1100	48	180	254
---	375	315	250	355CB		610	150	750	810	645	412	189	710	---	390	390	1100	48	180	254

Note:

1. All dimensions are in mm.
2. Open type ball bearing for frame size 250M to 355C
3. Dual Eye-bolts provided for frame 90S to 355C
4. Output in () is for optional frame size upon request
5. Data are subject to change without prior notice

B3

B3 Outline Dimension

Foot Mounted(B3)

Motor Type: AESV1S, AESV2S, AESV3S

Frame Size: 250M to 355C

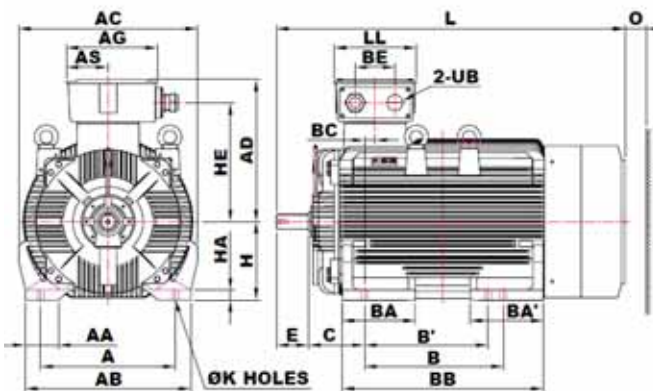
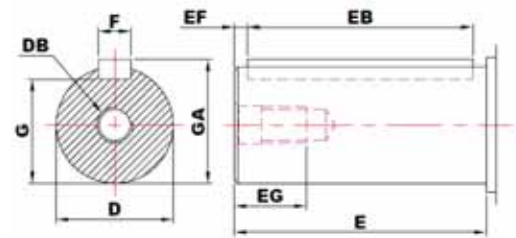

FIG. 6



FRAME SIZE	H	HA	HE	K	L	LL	O	UB	SHAFT EXTENSION								BEARING		
									D	E	EB	EF	EG	F	G	GA	DB	DRIVE END	OPPOSITE DRIVE END
250MA	250	30	322	24	921	255	105	M63x1.5	60	140	125	7.5	42	18	53	64	M20	6313C3	6313C3
250MC	250	30	322	24	921	255	105	M63x1.5	65	140	125	7.5	42	18	58	69	M20	6315C3	6313C3
280SA	280	35	354.5	24	1037.5	255	140	M63X1.5	65	140	125	7.5	40	18	58	69	M20	6314C3	6314C3
280SB	280	35	354.5	24	1037.5	255	140	M63X1.5	75	140	125	7.5	40	20	67.5	79.5	M20	6318C3	6316C3
280MA	280	35	354.5	24	1087.5	255	140	M63X1.5	65	140	125	7.5	40	18	58	69	M20	6314C3	6314C3
280MB	280	35	354.5	24	1087.5	255	140	M63X1.5	75	140	125	7.5	40	20	67.5	79.5	M20	6318C3	6316C3
315SA	315	35	430	28	1216	322	180	M63X1.5	65	140	125	7.5	40	18	58	69	M20	6316C3	6314C3
315SB	315	35	430	28	1246	322	180	M63X1.5	80	170	160	5	40	22	71	85	M20	6320C3	6316C3
315MA	315	35	430	28	1266	322	180	M63X1.5	65	140	125	7.5	40	18	58	69	M20	6316C3	6314C3
315MB	315	35	430	28	1296	322	180	M63X1.5	80	170	160	5	40	22	71	85	M20	6320C3	6316C3
315LA	315	45	430	28	1366	322	180	M63X1.5	65	140	125	7.5	40	18	58	69	M20	6316C3	6314C3
315LB	315	45	430	28	1396	322	180	M63X1.5	80	170	160	5	40	22	71	85	M20	6320C3	6316C3
315CA	315	45	485	28	1484	372	200	M72X2	75	140	125	7.5	40	20	67.5	79.5	M20	6316C3	6316C3
315CB	315	45	485	28	1514	372	200	M72X2	95	170	160	5	48	25	86	100	M24	6322C3	6322C3
315DA	315	45	485	28	1674	372	200	M72X2	75	140	125	7.5	40	20	67.5	79.5	M20	6316C3	6316C3
315DB	315	45	485	28	1704	372	200	M72X2	95	170	160	5	48	25	86	100	M24	6322C3	6322C3
355MA	355	45	540	28	1605	372	230	M72X2	80	170	140	5	40	22	71	85	M20	6318C3	6318C3
355MB	355	45	540	28	1645	372	230	M72X2	100	210	180	5	48	28	90	106	M24	6322C3	6322C3
355LA	355	45	540	28	1605	372	230	M72X2	80	170	140	5	40	22	71	85	M20	6318C3	6318C3
355LB	355	45	540	28	1645	372	230	M72X2	100	210	180	5	48	28	90	106	M24	6322C3	6322C3
355CA	355	45	540	28	1795	372	230	M72X2	80	170	140	5	40	22	71	85	M20	6318C3	6318C3
355CB	355	45	540	28	1835	372	230	M72X2	100	210	180	5	48	28	90	106	M24	6322C3	6322C3

Note:

1. All dimensions are in mm.
2. Tolerance of shaft end diameter D: 1) $\varnothing 55\sim\varnothing 100:m6$
3. Tolerance of shaft center high H : 1) 80~250: +0, -0.5, 2) 280~355: +0, -1
4. Data are subject to change without prior notice

V1 Outline Dimension

Flange Mounted(V1)

Motor Type: AESU1S, AESU2S, AESU3S

Frame Size: 80M to 225M

V1

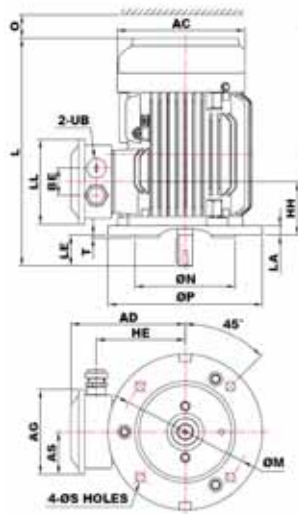

FIG. 1

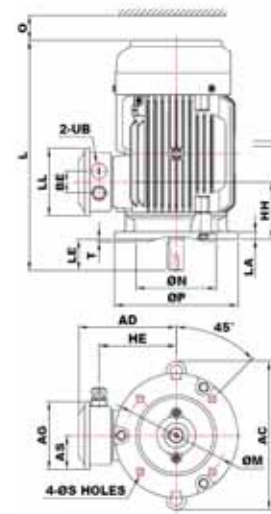
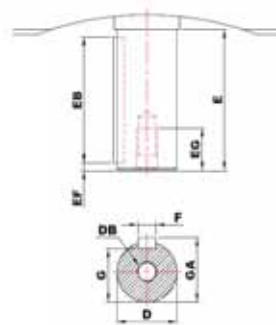

FIG. 2

Output (kW)				FRAME SIZE	FIG. NO	FLANGE DIMENSION								AC	AD	AG	AS	BE	HE
2P	4P	6P	8P			LA	LE	M	N	P	S	T							
0.75 1.1	0.55 0.75	0.55	0.18	80M	1	12	40	165	130	200	12	3.5	177	148	109	54.5	35	115	
1.5	1.1	0.75	0.37	90S		12	50	165	130	200	12	3.5	271	158	109	54.5	35	125	
2.2	1.5	1.1	0.55	90L		12	50	165	130	200	12	3.5	271	158	109	54.5	35	125	
3	2.2 3	1.5	0.75 1.1	100L		16	60	215	180	250	14.5	4	288.5	185.5	125	62.5	40	146	
3.7 4	3.7 4	2.2	1.5	112M		15	60	215	180	250	14.5	4	306.5	193	125	62.5	40	153.5	
5.5 7.5	5.5	3	2.2	132S		16	80	265	230	300	14.5	4	360	210.5	125	62.5	40	171	
---	7.5	3.7 4 5.5	3	132M		16	80	265	230	300	14.5	4	360	210.5	125	62.5	40	171	
11 15	11	7.5	3.7 4 5.5	160M	2	15	110	300	250	350	18.5	5	427	240.5	166	83	60	198	
18.5	15	11	7.5	160L		15	110	300	250	350	18.5	5	427	240.5	166	83	60	198	
22	18.5	---	---	180M		15	110	300	250	350	18.5	5	476	266.5	166	83	60	224	
---	22	15	11	180L		15	110	300	250	350	18.5	5	476	266.5	166	83	60	224	
30 37	30	18.5 22	15	200L		17	110	350	300	400	18.5	5	524	332	231	110.5	106	262	
---	37	---	18.5	225SC	3	20	140	400	350	450	18.5	5	574	358	231	110.5	106	288	
45	---	---	---	225MA		20	110	400	350	450	18.5	5	574	358	231	110.5	106	288	
---	45	30	22	225MC		20	140	400	350	450	18.5	5	574	358	231	110.5	106	288	

Note:

1. All dimensions are in mm.
2. Tolerance of N: $\varnothing 130\text{--}\varnothing 450$: j6
3. Pre-packed shielded ball bearing for frame size 80M to 225M
4. Dual Eye-bolts provided for frame 90S to 355L
5. Data are subject to change without prior notice

V1

V1 Outline Dimension

Flange Mounted(V1)

Motor Type: AESU1S, AESU2S, AESU3S

Frame Size: 80M to 225M



FIG. 3

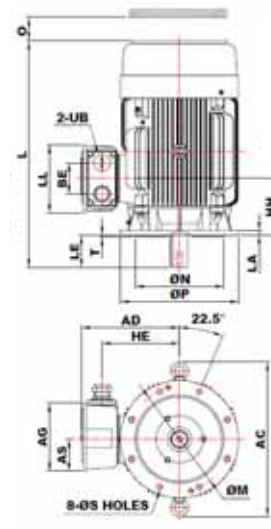
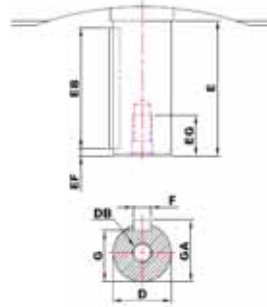

FIG. 4

FRAME SIZE	HH	L	LL	O	UB	SHAFT EXTENSION										BEARING	
						D	E	EB	EF	EG	F	G	GA	DB	DRIVE END	OPPOSITE DRIVE END	
80M	68.5	293	109	40	M20X1.5	19	40	32	4	16	6	15.5	21.5	M6	6204ZZC3	6204ZZC3	
90S	92	344.5	109	40	M20X1.5	24	50	40	5	19	8	20	27	M8	6205ZZC3	6205ZZC3	
90L	92	369.5	109	40	M20X1.5	24	50	40	5	19	8	20	27	M8			
100L	84	392	125	50	M25X1.5	28	60	50	5	22	8	24	31	M10	6206ZZC3	6206ZZC3	
112M	98	412.5	125	50	M25X1.5	28	60	50	5	22	8	24	31	M10	6306ZZC3	6306ZZC3	
132S	95	466	125	50	M25X1.5	38	80	70	5	28	10	33	41	M12	6308ZZC3	6306ZZC3	
132M	95	504	125	50	M25X1.5	38	80	70	5	28	10	33	41	M12			
160M	155	608	158	60	M32x 1.5	42	110	100	5	36	12	37	45	M16	6309ZZC3	6307ZZC3	
160L	155	652	158	60	M32x 1.5	42	110	100	5	36	12	37	45	M16			
180M	160	672	158	70	M32x 1.5	48	110	100	5	36	14	42.5	51.5	M16	6311ZZC3	6310ZZC3	
180L	160	710	158	70	M32x 1.5	48	110	100	5	36	14	42.5	51.5	M16			
200L	193	770	231	80	M50x 1.5	55	110	100	5	42	16	49	59	M20	6312ZZC3	6212ZZC3	
225SC	186.5	816	231	90	M50 x 1.5	60	140	125	7.5	42	18	53	64	M20	6313ZZC3	6213ZZC3	
225MA	186.5	811	231	90	M50 x 1.5	55	110	100	5	42	16	49	59	M20	6312ZZC3	6212ZZC3	
225MC	186.5	841	231	90	M50 x 1.5	60	140	125	7.5	42	18	53	64	M20	6313ZZC3	6213ZZC3	

Note:

1. All dimensions are in mm.
2. Tolerance of shaft end diameter D: 1) $\varnothing 19\sim\varnothing 28:j6$, 2) $\varnothing 38\sim\varnothing 48:k6$, 3) $\varnothing 55\sim\varnothing 65:m6$
3. Data are subject to change without prior notice

V1 Outline Dimension

Flange Mounted(V1)

Motor Type: AESU1S, AESU2S, AESU3S

Frame Size: 250M to 355L

V1

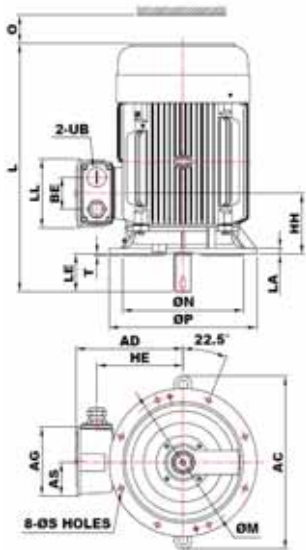

FIG. 5

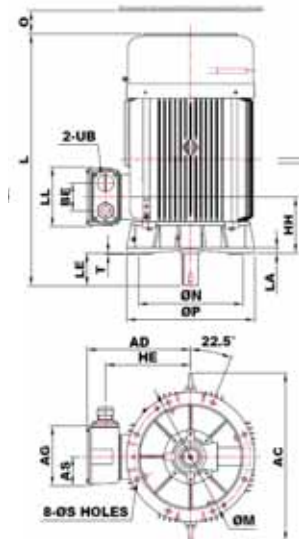
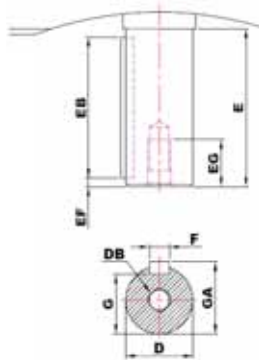

FIG. 6

Output (kW)				FRAME SIZE	FIG. NO	FLANGE DIMENSION								AC	AD	AG	AS	BE	HE
2P	4P	6P	8P			LA	LE	M	N	P	S	T							
55	---	---	---	250MA	5	22	140	500	450	550	18.5	5	642	400	255	122.5	119	322	
---	55	37	30	250MC		22	140	500	450	550	18.5	5	642	400	255	122.5	119	322	
75	---	---	---	280SA	6	22	140	500	450	550	18.5	5	713	433	255	122.5	119	354.5	
---	75	45	37	280SB		22	140	500	450	550	18.5	5	713	433	255	122.5	119	354.5	
90	---	---	---	280MA		22	140	500	450	550	18.5	5	713	433	255	122.5	119	354.5	
---	90	55	45	280MB		22	140	500	450	550	18.5	5	713	433	255	122.5	119	354.5	
110	---	---	---	315SA	7	25	140	600	550	660	24	6	660	527	336	163	140	430	
---	110	75	55	315SB		25	170	600	550	660	24	6	660	527	336	163	140	430	
132 (160)	---	---	---	315MA		25	140	600	550	660	24	6	660	527	336	163	140	430	
---	132 (160)	90 (110)	75	315MB		25	170	600	550	660	24	6	660	527	336	163	140	430	
160 200	---	---	---	315LA		25	140	600	550	660	24	6	660	527	336	163	140	430	
---	160 200	110 132 (160)	90 110	315LB		25	170	600	550	660	24	6	660	527	336	163	140	430	
220 250	---	---	---	355MA	8	30	170	740	680	800	24	6	980	645	412	189	180	540	
---	220 250	160 200 220	132 160	355MB		30	210	740	680	800	24	6	980	645	412	189	180	540	
315	---	---	---	355LA		30	170	740	680	800	24	6	980	645	412	189	180	540	
---	315	250	200 220	355LB		30	210	740	680	800	24	6	980	645	412	189	180	540	

Note:

1. All dimensions are in mm.
2. Tolerance of N: $\varnothing 130\text{--}\varnothing 450$: j6, $\varnothing 550\text{--}680$: js6
3. Open type ball bearing for frame size 250M to 355L
4. Output in () is for optional frame size upon request
5. Dual Eye-bolts provided for frame 90S to 355D
6. Data are subject to change without prior notice

V1

V1 Outline Dimension

Flange Mounted(B3)

Motor Type: AESU1S, AESU2S, AESU3S

Frame Size: 250M to 355L

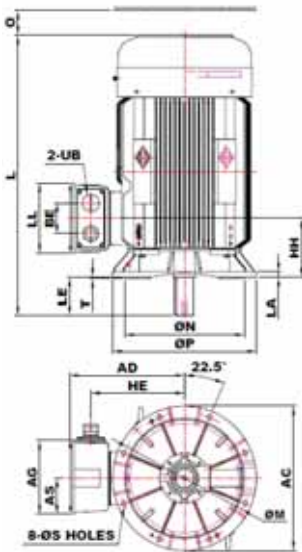

FIG. 7

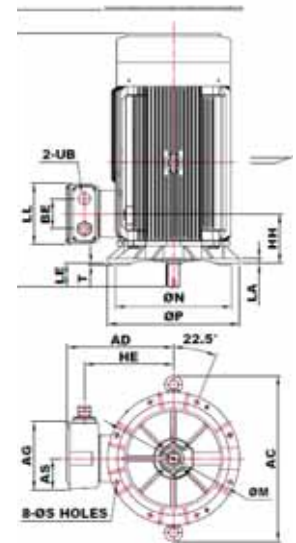
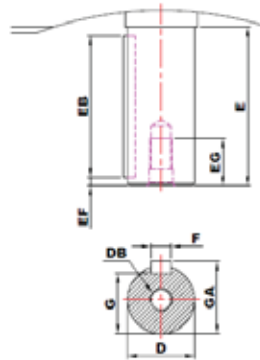

FIG. 8

FRAME SIZE	HH	L	LL	O	UB	SHAFT EXTENSION									BEARING	
						D	E	EB	EF	EG	F	G	GA	DB	DRIVE END	OPPOSITE DRIVE END
250MA	225.5	921	255	105	M63 x 1.5	60	140	125	7.5	42	18	53	64	M20	6313C3	6313C3
250MC	225.5	921	255	105	M63 x 1.5	65	140	125	7.5	42	18	58	69	M20	6315C3	6313C3
280SA	238	1037.5	255	140	M63X1.5	65	140	125	7.5	40	18	58	69	M20	6314C3	6314C3
280SB	238	1037.5	255	140	M63X1.5	75	140	125	7.5	40	20	67.5	79.5	M20	6318C3	6316C3
280MA	238	1087.5	255	140	M63X1.5	65	140	125	7.5	40	18	58	69	M20	6314C3	6314C3
280MB	238	1087.5	255	140	M63X1.5	75	140	125	7.5	40	20	67.5	79.5	M20	6318C3	6316C3
315SA	269	1216	322	180	M63X1.5	65	140	125	7.5	40	18	58	69	M20	6316C3	7314C3
315SB	269	1246	322	180	M63X1.5	80	170	160	5	40	22	71	85	M20	6320C3	7316C3
315MA	269	1266	322	180	M63X1.5	65	140	125	7.5	40	18	58	69	M20	6316C3	7314C3
315MB	269	1296	322	180	M63X1.5	80	170	160	5	40	22	71	85	M20	6320C3	7316C3
315LA	269	1366	322	180	M63X1.5	65	140	125	7.5	40	18	58	69	M20	6316C3	7314C3
315LB	269	1396	322	180	M63X1.5	80	170	160	5	40	22	71	85	M20	6320C3	7316C3
355MA	302	1605	372	230	M72X2	80	170	140	5	40	22	71	85	M20	6318C3	7318C3
355MB	302	1645	372	230	M72X2	100	210	180	5	48	28	90	106	M24	6322C3	7322C3
355LA	302	1605	372	230	M72X2	80	170	140	5	40	22	71	85	M20	6318C3	7318C3
355LB	302	1645	372	230	M72X2	100	210	180	5	48	28	90	106	M24	6322C3	7322C3

Note:

1. All dimensions are in mm.
2. Tolerance of shaft end diameter D: 1) $\varnothing 55\sim\varnothing 100:m6$
3. Data are subject to change without prior notice

B35 Outline Dimension

Foot & Flange Mounted(B35)

Motor Type: AESV1S-LA, AESV2S-LA, AESV3S-LA

Frame Size: 80M to 225M

B35

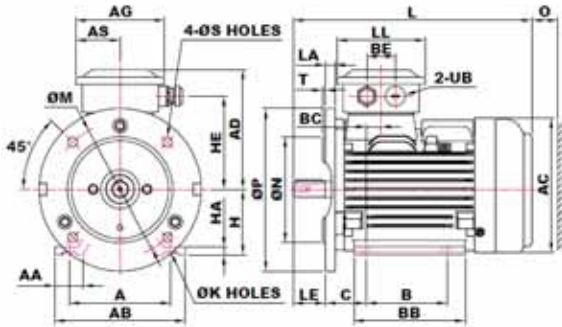

FIG. 1

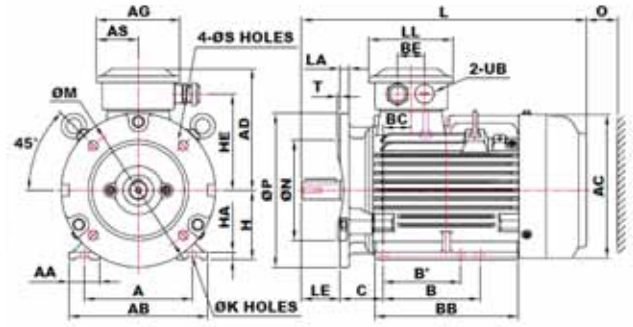
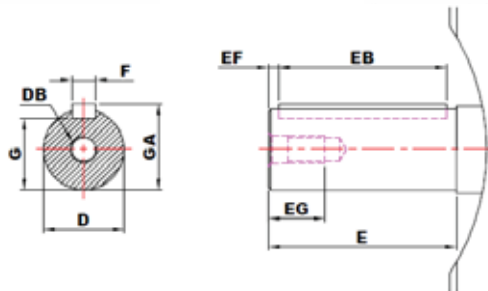

FIG. 2



Output (kW)				FRAME SIZE	FIG. NO	FLANGE DIMENSION								A	AA	AB	AC	AD	AG	AS	B	B'	BA	BA'	BB
2P	4P	6P	8P			LA	LE	M	N	P	S	T													
0.75 1.1	0.55 0.75	0.55	0.18	80M	1	12	40	165	130	200	12	3.5	125	34.5	161	177	148	109	54.5	100	---	---	---	137	
1.5	1.1	0.75	0.37	90S	2	12	50	165	130	200	12	3.5	140	40	180	197	158	109	54.5	100	---	---	---	161	
2.2	1.5	1.1	0.55	90L		12	50	165	130	200	12	3.5	140	40	180	197	158	109	54.5	125	100	---	---	---	186
3	2.2 3	1.5	0.75 1.1	100L		16	60	215	180	250	14.5	4	160	40	200	219	185.5	125	62.5	140	---	---	---	---	181
3.7 4	3.7 4	2.2	1.5	112M		15	60	215	180	250	14.5	4	190	45	235	235	193	125	62.5	140	---	---	---	---	186
5.5 7.5	5.5	3	2.2	132S		16	80	265	230	300	14.5	4	216	57	263	273	210.5	125	62.5	140	---	---	---	---	184
---	7.5	3.7 4 5.5	3	132M		16	80	265	230	300	14.5	4	216	57	263	273	210.5	125	62.5	178	140	---	---	---	222
11 15	11	7.5	3.7 4 5.5	160M	3	15	110	300	250	350	18.5	5	254	60	300	317	240.5	166	83	210	---	57.5	57.5	256	
18.5	15	11	7.5	160L		15	110	300	250	350	18.5	5	254	60	300	317	240.5	166	83	254	210	57.5	101.5	300	
22	18.5	---	---	180M		15	110	300	250	350	18.5	5	279	65	330	354	266.5	166	83	241	---	62	62	292	
---	22	15	11	180L		15	110	300	250	350	18.5	5	279	65	330	354	266.5	166	83	279	241	62	100	330	
30 37	30	18.5 22	15	200L		17	110	350	300	400	18.5	5	318	70	378	398	332	231	110.5	305	---	76	76	365	
---	37	---	18.5	225SC	4	20	140	400	350	450	18.5	5	356	75	431	449	358	231	110.5	286	---	90	90	350	
45	---	---	---	225MA		20	110	400	350	450	18.5	5	356	75	431	449	358	231	110.5	311	286	90	115	375	
---	45	30	22	225MC		20	140	400	350	450	18.5	5	356	75	431	449	358	231	110.5	311	286	90	115	375	

Note:

1. All dimensions are in mm.
2. Tolerance of N: Ø130~Ø450: j6
3. Pre-packed shielded ball bearing for frame size 80M to 225M
4. Dual Eye-bolts provided for frame 90S to 355C
5. Data are subject to change without prior notice

B35

B35 Outline Dimension

Foot & Flange Mounted(B35)
 Motor Type: AESV1S-LA, AESV2S-LA, AESV3S-LA
 Frame Size: 80M to 225M

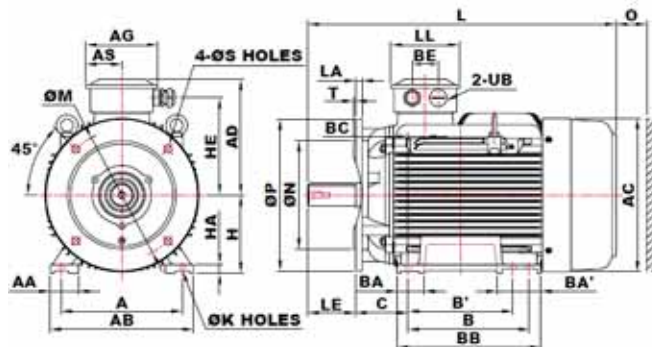

FIG. 3

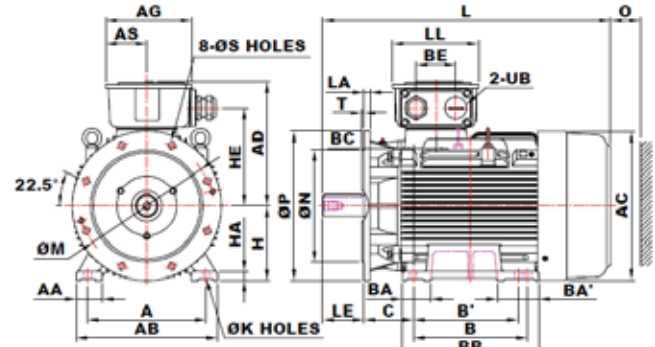
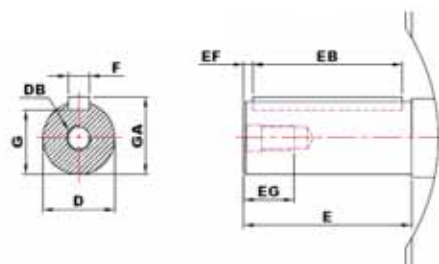

FIG. 4



FRAME SIZE	BC	BE	C	H	HA	HE	K	L	LL	O	UB	SHAFT EXTENSION								BEARING		
												D	E	EB	EF	EG	F	G	GA	DB	DRIVE END	OPPOSITE DRIVE END
80M	18.5	35	50	80	10	115	10	293	109	40	M20x1.5	19	40	32	4	16	6	15.5	21.5	M6	6204ZZC3	6204ZZC3
90S	36	35	56	90	10	125	10	344.5	109	40	M20x1.5	24	50	40	5	19	8	20	27	M8	6205ZZC3	6205ZZC3
90L	36	35	56	90	10	125	10	369.5	109	40	M20x1.5	24	50	40	5	19	8	20	27	M8		
100L	21	40	63	100	12	146	12	392	125	50	M25x1.5	28	60	50	5	22	8	24	31	M10	6206ZZC3	6206ZZC3
112M	28	40	70	112	13	153.5	12	412.5	125	50	M25x1.5	28	60	50	5	22	8	24	31	M10	6306ZZC3	6306ZZC3
132S	6	40	89	132	16	171	12	466	125	50	M25x1.5	38	80	70	5	28	10	33	41	M12	6308ZZC3	6306ZZC3
132M	6	40	89	132	16	171	12	504	125	50	M25x1.5	38	80	70	5	28	10	33	41	M12		
160M	38	60	108	160	18	198	14.5	608	158	60	M32x1.5	42	110	100	5	36	12	37	45	M16	6309ZZC3	6307ZZC3
160L	38	60	108	160	18	198	14.5	652	158	60	M32x1.5	42	110	100	5	36	12	37	45	M16		
180M	39	60	121	180	20	224	14.5	672	158	70	M32x1.5	48	110	100	5	36	14	42.5	51.5	M16	6311ZZC3	6310ZZC3
180L	39	60	121	180	20	224	14.5	710	158	70	M32x1.5	48	110	100	5	36	14	42.5	51.5	M16		
200L	60	106	133	200	24	262	18.5	770	231	80	M50x1.5	55	110	100	5	42	16	49	59	M20	6312ZZC3	6212ZZC3
225SC	37.5	106	149	225	28	288	18.5	816	231	90	M50x1.5	60	140	125	7.5	42	18	53	64	M20	6313ZZC3	6213ZZC3
225MA	37.5	106	149	225	28	288	18.5	811	231	90	M50x1.5	55	110	100	5	42	16	49	59	M20	6312ZZC3	6212ZZC3
225MC	37.5	106	149	225	28	288	18.5	841	231	90	M50x1.5	60	140	125	7.5	42	18	53	64	M20	6313ZZC3	6213ZZC3

Note:

- All dimensions are in mm.
- Tolerance of shaft end diameter D: 1) $\varnothing 19\sim\varnothing 28:j6$, 2) $\varnothing 38\sim\varnothing 48:k6$, 3) $\varnothing 55\sim\varnothing 65:m6$
- Tolerance of shaft center high H : +0, -0.5
- Data are subject to change without prior notice

B35 Outline Dimension

Foot & Flange Mounted(B35)

Motor Type: AESV1S-LA, AESV2S-LA, AESV3S-LA

Frame Size 250M to 355C

B35

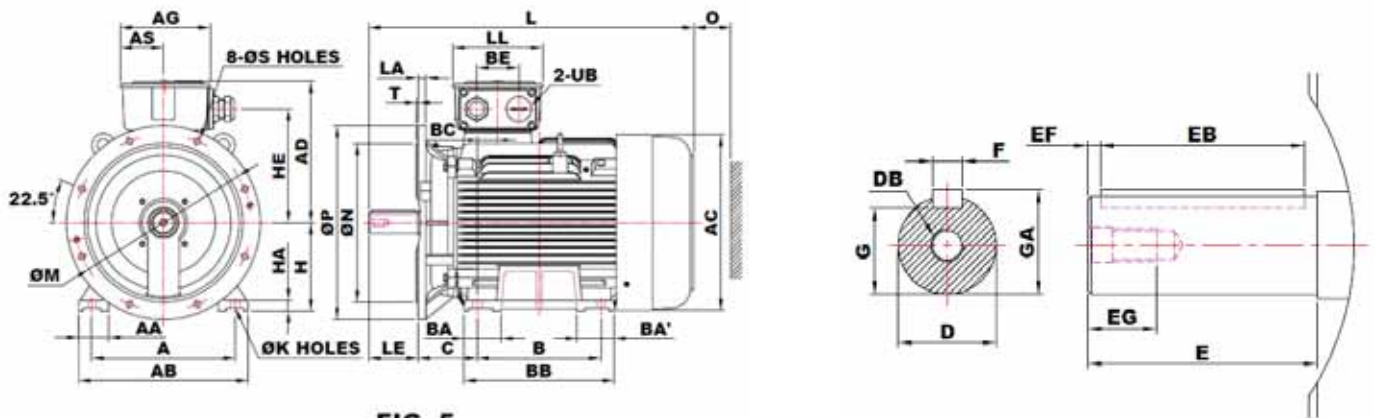

FIG. 5

Output (kW)				FRAME SIZE	FIG. NO	FLANGE DIMENSION								A	AA	AB	AC	AD	AG	AS	B	B'	BA	BA'	BB
2P	4P	6P	8P			LA	LE	M	N	P	S	T													
55	---	---	---	250MA	5	22	140	500	450	550	18.5	5	406	85	480	499	400	255	122.5	349	---	105	105	425	
---	55	37	30	250MC		22	140	500	450	550	18.5	5	406	85	480	499	400	255	122.5	349	---	105	105	425	
75	---	---	---	280SA		22	140	500	450	550	18.5	5	457	110	560	550	433	255	122.5	368	---	110	110	445	
---	75	45	37	280SB		22	140	500	450	550	18.5	5	457	110	560	550	433	255	122.5	368	---	110	110	445	
90	---	---	---	280MA		22	140	500	450	550	18.5	5	457	110	560	550	433	255	122.5	419	---	130	137	495	
---	90	55	45	280MB		22	140	500	450	550	18.5	5	457	110	560	550	433	255	122.5	419	---	130	137	495	
110	---	---	---	315SA	6	25	140	600	550	660	24	6	508	115	615	660	527.5	336	163	406	---	210	210	620	
---	110	75	55	315SB		25	170	600	550	660	24	6	508	115	615	660	527.5	336	163	406	---	210	210	620	
132 (160)	---	---	---	315MA		25	140	600	550	660	24	6	508	115	615	660	527.5	336	163	457	---	240	240	670	
---	132 (160)	90 (110)	75	315MB		25	170	600	550	660	24	6	508	115	615	660	527.5	336	163	457	---	240	240	670	
160 200	---	---	---	315LA		25	140	600	550	660	24	6	508	130	630	660	527.5	336	163	508	---	230	230	770	
---	160 200	110 132 (160)	90 110	315LB		25	170	600	550	660	24	6	508	130	630	660	527.5	336	163	508	---	230	230	770	
(220) (250)	---	---	---	315CA		30	140	600	550	660	24	6	508	150	650	682	590	412	189	710	---	335	335	900	
---	(220) (250)	(200) (220)	(132) (160)	315CB		30	170	600	550	660	24	6	508	150	650	682	590	412	189	710	---	335	335	900	
(315)	---	---	---	315DA		30	140	600	550	660	24	6	508	150	650	682	590	412	189	900	---	180	250	1060	
---	(315)	(250)	(200) (220)	315DB		30	170	600	550	660	24	6	508	150	650	682	590	412	189	900	---	180	250	1060	
220 250	---	---	---	355MA		30	170	740	680	800	24	6	610	150	750	810	645	412	189	---	560	330	330	910	
---	220 250	160 200 220	132 160	355MB		30	210	740	680	800	24	6	610	150	750	810	645	412	189	---	560	330	330	910	
315	---	---	---	355LA	30	170	740	680	800	24	6	610	150	750	810	645	412	189	630	---	330	330	910		
---	315	250	200 220	355LB	30	210	740	680	800	24	6	610	150	750	810	645	412	189	630	---	330	330	910		
375	---	---	---	355CA	30	170	740	680	800	24	6	610	150	750	810	645	412	189	710	---	390	390	1100		
---	375	315	250	355CB	30	210	740	680	800	24	6	610	150	750	810	645	412	189	710	---	390	390	1100		

Note:

1. All dimensions are in mm.
2. Tolerance of N: Ø130~Ø450: j6 , Ø550~680: js6
3. Open type ball bearing for frame size 250M to 355C
4. Dual Eye-bolts provided for frame 90S to 355C
5. Output in () is for optional frame size upon request
6. Data are subject to change without prior notice

B35

B35 Outline Dimension

Foot & Flange Mounted(B35)
Motor Type: AESV1S-LA, AESV2S-LA, AESV3S-LA
Frame Size 250M to 355C

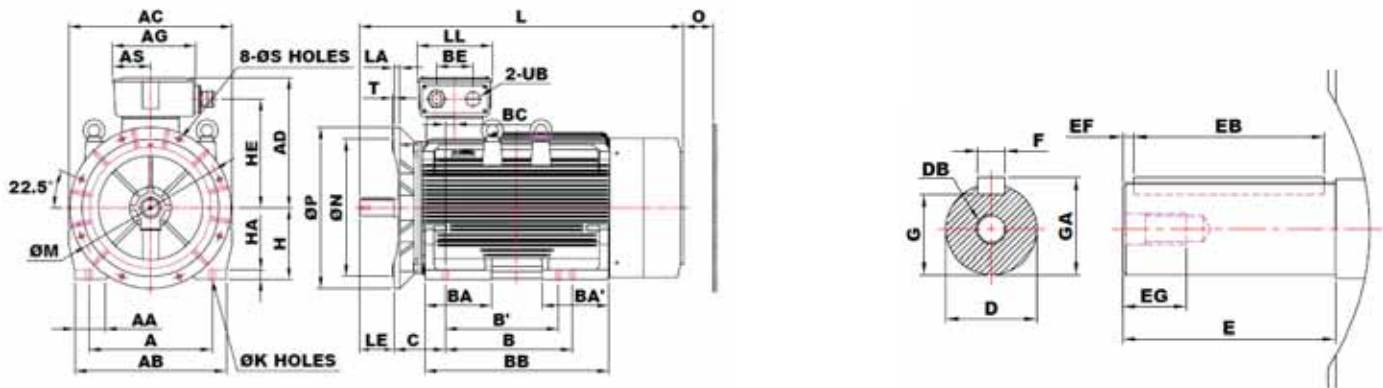

FIG. 6

FRAME SIZE	BC	BE	C	H	HA	HE	K	L	LL	O	UB	SHAFT EXTENSION								BEARING		
												D	E	EB	EF	EG	F	G	GA	DB	DRIVE END	OPPOSITE DRIVE END
250MA	57.5	119	168	250	30	322	24	921	255	105	M63x1.5	60	140	125	7.5	42	18	53	64	M20	6313C3	6313C3
250MC	57.5	119	168	250	30	322	24	921	255	105	M63x1.5	65	140	125	7.5	42	18	58	69	M20	6315C3	6313C3
280SA	48	119	190	280	35	354.5	24	1037.5	255	140	M63X1.5	65	140	125	7.5	40	18	58	69	M20	6314C3	6314C3
280SB	48	119	190	280	35	354.5	24	1037.5	255	140	M63X1.5	75	140	125	7.5	40	20	67.5	79.5	M20	6318C3	6316C3
280MA	48	119	190	280	35	354.5	24	1087.5	255	140	M63X1.5	65	140	125	7.5	40	18	58	69	M20	6314C3	6314C3
280MB	48	119	190	280	35	354.5	24	1087.5	255	140	M63X1.5	75	140	125	7.5	40	20	67.5	79.5	M20	6318C3	6316C3
315SA	53	140	216	315	35	430	28	1216	322	180	M63X1.5	65	140	125	7.5	40	18	58	69	M20	6316C3	6314C3
315SB	53	140	216	315	35	430	28	1246	322	180	M63X1.5	80	170	160	5	40	22	71	85	M20	6320C3	6316C3
315MA	53	140	216	315	35	430	28	1266	322	180	M63X1.5	65	140	125	7.5	40	18	58	69	M20	6316C3	6314C3
315MB	53	140	216	315	35	430	28	1296	322	180	M63X1.5	80	170	160	5	40	22	71	85	M20	6320C3	6316C3
315LA	53	140	216	315	45	430	28	1366	322	180	M63X1.5	65	140	125	7.5	40	18	58	69	M20	6316C3	6314C3
315LB	53	140	216	315	45	430	28	1396	322	180	M63X1.5	80	170	160	5	40	22	71	85	M20	6320C3	6316C3
315CA	68	180	216	315	45	485	28	1484	372	200	M72X2	75	140	125	7.5	40	20	67.5	79.5	M20	6316C3	6316C3
315CB	68	180	216	315	45	485	28	1514	372	200	M72X2	95	170	160	5	48	25	86	100	M24	6322C3	6322C3
315DA	68	180	216	315	45	485	28	1674	372	200	M72X2	75	140	125	7.5	40	20	67.5	79.5	M20	6316C3	6316C3
315DB	68	180	216	315	45	485	28	1704	372	200	M72X2	95	170	160	5	48	25	86	100	M24	6322C3	6322C3
355MA	48	180	254	355	45	540	28	1605	372	230	M72X2	80	170	140	5	40	22	71	85	M20	6318C3	6318C3
355MB	48	180	254	355	45	540	28	1645	372	230	M72X2	100	210	180	5	48	28	90	106	M24	6322C3	6322C3
355LA	48	180	254	355	45	540	28	1605	372	230	M72X2	80	170	140	5	40	22	71	85	M20	6318C3	6318C3
355LB	48	180	254	355	45	540	28	1645	372	230	M72X2	100	210	180	5	48	28	90	106	M24	6322C3	6322C3
355CA	48	180	254	355	45	540	28	1795	372	230	M72X2	80	170	140	5	40	22	71	85	M20	6318C3	6318C3
355CB	48	180	254	355	45	540	28	1835	372	230	M72X2	100	210	180	5	48	28	90	106	M24	6322C3	6322C3

Note:

1. All dimensions are in mm.
2. Tolerance of shaft end diameter D: 1) Ø55~Ø100:m6
3. Tolerance of shaft center high H : 1) 80~250: +0, -0.5, 2) 280~355: +0, -1
4. Data are subject to change without prior notice

General Electrical Formulas

	Formula	Units	Definitions/ Notes
Output	1HP=746W=0.746kW		HP: horsepower
Current	$I = \frac{E}{R}$	I in A	E: volt R: Ohm
Input power	$P_{in} = E \cdot I \cdot \cos \theta \dots\dots\dots (1 \Phi)$ $P_{in} = \sqrt{3} \cdot E \cdot I \cdot \cos \theta \dots\dots\dots (3 \Phi)$	P_{in} in W	E: volt I: ampere
Output power	$P_{out} = E \cdot I \cdot \cos \theta \dots\dots\dots (1 \Phi)$ $P_{out} = \sqrt{3} \cdot E \cdot I \cdot \cos \theta \dots\dots\dots (3 \Phi)$	P_{out} in W	η : efficiency $\cos \theta$: power factor
Efficiency	$= \frac{P_{out}}{P_{in}} 100\% = \frac{P_{in} - P_{loss}}{P_{in}} 100\%$	P_{loss} in W	
Power factor	$\cos \theta = \frac{P_{in}}{\sqrt{3} \cdot E \cdot I} 100\% \dots\dots\dots (3 \Phi)$		
Synchronous speed	$N_s = \frac{120f}{P}$	N_s in min^{-1}	f: frequency of the power supply P: poles
Slip	$S = \frac{N_s - N}{N_s} 100\%$		N: motor speed
Torque	$T = \frac{974kW}{N}$	T in kgf-m	1 kgf-m=9.8 N-m
Power	$P = 1.027NT$	P in W	
Starting time	$t_s = \frac{GD^2N}{375(T_M - T_L)}$	t_s in sec GD^2 in kgm^2	GD^2 : inertia of system T_M : torque of motor
Braking time	$t_B = \frac{GD^2N}{375(T_M + T_L)}$	t_B in sec	T_L : torque of load
Reactive power absorbed by the motor	$Q = \sqrt{3} \cdot E \cdot I \cdot \sin \theta \dots\dots\dots (3 \Phi)$	Q in VAR	
Sound power level	$L_w = 10 \log\left(\frac{P}{P_o}\right)$ $(P_o = 10^{-12}W)$	L_w in dB	
Sound pressure level	$L_p = 20 \log\left(\frac{P}{P_o}\right)$ $(P_o = 2 \cdot 10^{-5}P_a)$	L_p in dB	$P_a=1 \text{ N/m}^2$

International Mounting Code (IM)

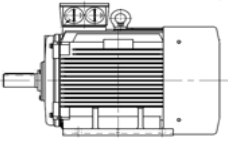
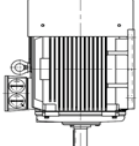
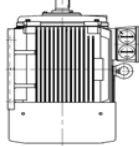
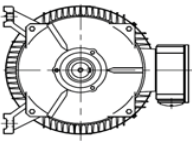
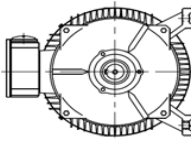
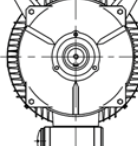
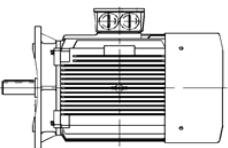
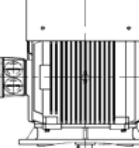
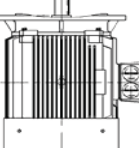
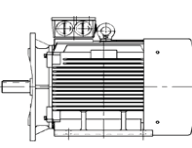
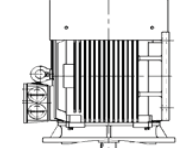
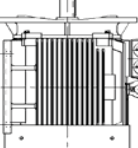
Foot-Mounted					
					
IM B3 (IM 1001)	IM V5 (IM 1011)	IM V6 (IM 1031)	IM B6 (IM 1051)	IM B7 (IM 1061)	IM B8 (IM 1071)
Flange-Mounted			Foot & Flange Mounted		
					
IM B5 (IM 3001)	IM V1 (IM 3011)	IM V3 (IM 3031)	IM B35 (IM 2001)	IM V15 (IM 2011)	IM V36 (IM 2031)

Enquiry Form

Customer Name : _____ Company : _____

Contact Number : _____

Motor Specification Required

Efficiency Class (IE) : IE 1 IE 2 IE 3

Output : _____ kW / HP

Voltage : _____ Volts Frequency : _____ Hz

Poles : 2 4 6 8 Others: _____

Location : Indoor Outdoor Application : _____

Mounting : _____ (eg. B3,V1,B35)

Ingress Protection : IP55 IP56 Others: _____

Insulation Class : Class F (155 °C) Class H (180 °C)

Ambient Temperature : _____ °C

Temperature Rise : Class B (80 °C) Class F(105 °C)

Starting Method : Direct-On-Line Star-Delta Inverter

Inverter : IEC 60034-17 Torque : Constant / Variable

IEC 60034-25 Speed Range : From: _____ To: _____ Hz

Drive Method : Direct Coupling Belt drive Others: _____

Quantity : _____